

Contents	Page	Contents	Page
1	Scope	8	
1.4	Effective Dates	8	
1.7	Equipment Not Covered	8	
2	References & Related Standards	9	
3	Definitions	10	
4	Hazards	16	
5	Safety Requirements and/or Measures	18	
5.1	Structural and Stability Calculations	18	
5.1.1	General	18	
5.1.2	Loads and Forces	18	
5.1.3	Load Combinations and Safety Factors	22	
5.1.4	Structural Calculations	23	
5.1.5	Stability Calculations	23	
5.2	General Machine Requirements, Base Frame, Chassis and Mast	23	
5.2.1	General Machine Requirements	23	
5.2.2	Base Frame and Chassis	24	
5.2.3	Mast Structure	25	
5.2.4	Mast Design with regard to Erection	25	
5.2.5	Mast Ties	26	
5.3	Work Platform	26	
5.3.1	General	26	
5.3.2	Guarding	26	
5.3.3	Access	27	
5.3.4	Multilevel Work Platforms	27	
5.4	Drive Systems for Elevation	28	
5.4.1	General	28	
5.4.2	Rack and Pinion Drive System	29	
5.4.3	Ratchet Drive Systems	29	
5.4.4	Screw Drive Systems	30	
5.4.5	Braking System	31	
5.4.6	Buffers	32	
5.5	Means to Prevent the Work Platform From Falling with Overspeed	32	
5.5.1	General	32	
5.5.2	Overspeed Safety Device	33	
5.5.3	Multiple Drive Units	33	
5.6	Means for Emergency Lowering and Raising the Work Platform	34	
5.7	Overload/Moment Device	35	
5.8	Electrical Systems	36	
5.8.1	General	36	
5.8.2	Safety Switches	36	
5.8.3	Control Systems	37	
5.9	Drive Systems Powered by Internal Combustion Engines	37	
5.10	Hydraulic Systems	37	
5.10.1	General	37	
5.10.2	Hydraulic Cylinders	38	
5.11	Special Requirements for Safety Devices That Depend on Auxiliary Circuits	38	
5.12	Travel Limit Switches	38	
5.13	Controls	39	
6	Verification of Safety Requirements And/Or Measures for Each New Model of MCWP	39	
6.1	Design Check	39	
6.2	Practical Tests	40	
6.2.1	General	40	
6.2.2	Stability Tests	40	
7	Information for Use	41	
7.1	Operating Manual	41	
7.1.2	Content of the Operating Manual	41	
7.2	Marking	45	
7.2.1	General	45	
7.2.2	Information, Non Varying	45	
7.2.3	Information, Varying	46	
7.3	Responsibilities of Dealers	46	
7.4	Responsibilities of Owners	48	
7.5	Responsibilities of Users	50	
7.6	Responsibilities of Operators	55	
7.7	Responsibilities of Lessors	57	
7.8	Responsibilities of Lessees	57	
7.9	Responsibilities of Brokers	58	
Annex A	Informative for Structural Calculations	59	
Annex B	Special Requirements for Multilevel Work Platforms	61	
Annex C	Requirements for Electrical And Electronic Aspects for Overload Detection Devices	63	
Annex D	Minimum Safe Approach Distances	66	

1 Scope This standard applies to Mast Climbing Work Platforms that are primarily used to position personnel, along with their necessary tools and materials, to perform their work. (See Figure 1 on page 14 for typical examples of equipment covered.) Platforms may be adjustable by manual or powered means.

1.1

This standard is applicable to work platforms which are elevated by a drive system and guided by and move along their supporting masts, where the mast may or may not require lateral restraint from separate supporting structures.

1.2

This standard is applicable to any combination of the following alternatives:

- a) one or more masts.
- b) mast tied or untied.
- c) mast of fixed or variable length.
- d) masts vertical or inclined between 0° and 30° to the vertical.
- e) masts which are standing or hanging.
- f) movable or static base (chassis, or base frame).
- g) manually or power operated elevation.
- h) towed or self powered ground travel on site, excluding road traffic regulation requirements.
- i) driven using electric, pneumatic, hydraulic motors or internal combustion engines.

1.3

This standard identifies the hazards arising during the various phases in the life of such equipment and describes methods for the elimination or reduction of these hazards and for the use of safe working practices.

1.4 Effective Dates

1.4.1 Design, manufacture and remanufacture requirements

The design and manufacturing requirements of this Standard will apply to all Mast Climbing Work Platform's (MCWP's) manufactured on or after the effective date. MCWP's remanufactured on or after the effective date of this Standard shall comply with the requirements of this Standard.

1.4.2 Rebuild / recondition requirements

Rebuilt / reconditioned MCWP's shall comply with the Standard in effect as of the date of their original manufacture.

1.4.3 Installation requirements

The installation requirements of this Standard apply to all MCWP's installed on or after the effective date.

1.4.4 Responsibilities for dealers, owners, users, operators, lessors, lessees and brokers

All provisions detailed for dealers, owners, users, operators, lessors, lessees and brokers apply to both new and existing units delivered by sale, lease, rental or any form of beneficial use on or after the effective date.

1.5

This standard does not specify the requirements for dealing with the hazards involved in the maneuvering, erection or dismantling, fixing or removing of any materials or equipment, which are not part of the Mast Climbing Work Platform (MCWP). Neither does it deal with the handling of specific hazardous materials.

1.6

This standard does not specify the requirements for delivering persons and materials to fixed landing levels. Such equipment is referred to as lifts, hoists, or transport platforms and are dealt with by other standards.

1.7 Equipment Not Covered

This standard does not apply to equipment listed below:

- a) Ladder and ladder stands such as those covered in American National Standards for Ladder and Ladder Stands. ANSI A14series.
- b) Scaffolding such as those covered in American National Standard for Construction and Demolition Operations Scaffolding Safety Requirements, ANSI A10.8.
- c) Vehicle mounted elevating and rotating aerial platforms such as those covered in American National Standard for Vehicle Mounted Elevating and Rotating Aerial Devices, ANSI/SIA A92.2.
- d) Non self-propelled elevating aerial platforms such as those covered in American National Standard for Manually Propelled Elevating Aerial Platforms, ANSI/SIA A92.3.
- e) Self propelled elevating aerial platforms such as those covered in American National Standards for Boom Supported Elevating Work Platforms, ANSI/SIA A92.5.
- f) Self propelled elevating aerial platforms such as those covered in American National Standard

for Self Propelled Elevating Work Platforms, ANSI/SIA A92.6.

g) Safety requirements for airline ground support vehicle mounted vertical lift devices, American National Standard for Airline Ground Support Vehicle Mounted Vertical Lift Devices, ANSI/SIA A92.7.

h) Vehicle Mounted Bridge Inspection and Maintenance Devices, ANSI/SIA A92.8.

i) Transport Platforms such as those covered in American National Standard for Transport Platforms, ANSI/SIA A92.10

j) Suspended Powered Platforms for Exterior Building Maintenance, ANSI A120.1.

k) Vertically adjustable equipment used primarily to raise and lower materials and equipment from one elevation to another such as American National Standards in the A17 and B56 series.

l) Fire fighting equipment such as that covered in American National Standard for Automotive Fire Apparatus, ANSI/NFPA 1901.

m) Construction and demolition operation/digger derricks such as those covered in American National Standard for Construction and Demolition Digger Derricks Safety Requirements, Definitions and Specifications, ANSI A10.31.

2 References & Related Standards

2.1 Referenced Standards

This standard is intended to be used in conjunction with the following Standards. When these referenced standards are superseded by a revision approved by the appropriate authority, the revision shall apply to Mast Climbing Work Platforms manufactured on or after the effective date of the revision.

ANSI Z535.1, Z535.2, Z535.3 and Z535.4 Safety Signs and Colors

ANSI/ASME B15.1 Safety Standard for Mechanical Power Transmission Apparatus

ANSI/AWS D1.1 Structural Welding Code Steel

ANSI/AWS D1.2 Structural Welding Code Aluminum.

ANSI/NFPA 70 National Electrical Code

ANSI/NFPA 505 Powered Industrial Trucks, Including Type Designations, Areas of Use, Maintenance, and Operation

AISC-ASD Manual of Steel Construction - Allowable Stress Design.

AISC-LRFD Load and Resistance Factor Design Specification for Structural Steel Buildings

ANSI/ASCE 7-02 Minimum Design Loads for Buildings and Other Structures.

ANSI/NFPA 1901 Automotive Fire Apparatus

ANSI/AFBMA 9 Ball Bearings, Load Ratings and fatigue Life for.

ASTM A535 Standard Specifications for Special-Quality Ball and Roller Bearings Steel

ASTM A295 Standard Specifications for High-Carbon Anti-Friction Bearing Steel

SAE J514 Hydraulic Tubes Fittings

SAE J517D Hydraulic Hoses

ISO 76 Rolling Bearings-Static Load Ratings

ISO 281 Rolling Bearings-Dynamic load ratings and rating life

ASTM SI 10-02 Metric Practice Guide

OSHA-CFR Subpart L Scaffolds 1926.450

2.2 Related Standards

The standards listed here are for information only and are not essential for the completion of the requirements of this standard:

ANSI/SIA A92.2 2001, Vehicle Mounted Elevating and Rotating Aerial Devices

ANSI/SIA A92.3 2006, Manually Propelled Elevating Aerial Platforms

ANSI/SIA A92.5 2006, Boom Supported Elevating Work Platforms

ANSI/SIA A92.6 2006, Self Propelled Elevating Work Platforms

ANSI/SIA A92.7 1998, Airline Ground Support Vehicle Mounted Vertical Lift Devices

ANSI/SIA A92.8 2006, Vehicle Mounted Bridge Inspection and Maintenance Devices

ANSI/SIA A92.10 2008, Transport Platforms

ANSI A10.8 2001, Construction and Demolition Operations Scaffolding Safety Requirements

2.3 Referenced Scaffold Industry Association Publication(s)

The standard is intended to be used in conjunction with the following SIA publication(s): ANSI/SIA A92.9 Manual of Responsibilities for Dealers, Owners, Users, Operators, Lessors, Lessees and Brokers of Mast Climbing Work Platforms.

3 Definitions

For the purposes of this standard the following terms and definitions apply:

Note: The terms, which are used in this standard, with reference to the definitions below, are indicated in figures 1 and 2.

3.1 Authorized personnel (authorized person): Personnel approved or assigned to perform a specific type of duty or duties at a specific location or locations at a work site.

3.2 Available platform area: Area of the work platform measured at the work platform floor level.

3.3 Base frame: That part of the MCWP, which provides support for the mast and elevating assembly.

3.4 Broker: An independent business entity or person that arranges a lease or transfer of ownership of a MCWP, but does not own the MCWP. If the entity or person is an employee of the buyer, seller, lessor or lessee of the MCWP, he shall not be considered a broker.

3.5 Buffer: A device designed to stop the vertical movement of the platform beyond its normal limit of travel by storing or by absorbing and dissipating the kinetic energy of the platform.

3.6 Chassis: That part of the MCWP which provides mobility and support for the mast and elevating assembly.

3.7 Competent person: One who is capable of identifying existing and predictable hazards in the surroundings or working conditions that are unsanitary, hazardous or dangerous to employees and who has the authority to take prompt corrective measures to eliminate such hazards.

3.8 Counter roller: A roller used to counteract the gear meshing separation forces between a rack and pinion.

3.9 Dealer: A person or entity who buys, rents or leases from a manufacturer or distributor and who generally sells, rents, erects, and services MCWPs.

3.10 Delivery: Transfer of care, control and custody of the MCWP from one person or entity to another person or entity.

3.11 Elevating assembly: The platform, drive mechanisms and all other components that travel vertically on the mast.

3.12 Equivalent entity: An organization, agency, or individual who, by possession of an appropriate technical degree, certificate, professional standing, or skill, and who, by knowledge, training, and experience, has equivalent ability to deal with the problems relating to the subject matter, the work or the project of the entity referenced.

3.13 Exposed side: A side of the platform that is a greater distance from a building wall or structure than that allowed by Local, State and Federal codes and ordinances for guardrail requirements.

3.14 Familiarization: Providing information regarding the control functions and safety devices for the MCWP to a competent person or the operator who will control the movement of the MCWP being delivered.

3.15 Guardrail system: A vertical barrier intended to protect personnel and objects from falling to lower levels.

3.16 Guides: The parts of the mast which provide guiding for the work platform.

3.17 Hazardous location: Any location that contains, or has the potential to contain, an explosive or flammable atmosphere as defined in ANSI/NFPA 505 Powered Industrial Trucks.

3.18 Instability: A condition in which the sum of the moments which tend to overturn the MCWP is equal to or exceeds the sum of the moments tending to resist overturning.

3.19 Interlock: A control or mechanism that, under specified conditions, automatically allows or prevents the operation of another control or mechanism.

3.20 Lessee: A person(s) or entity to whom a MCWP is provided by lease, rental, loan, or other arrangement. A lessee may also be a user or operator.

3.21 Lessor: A person(s) or entity who leases, rents, loans, or otherwise provides a MCWP to another party for the beneficial use of that party (the user). A lessor may also be a dealer, owner, lessee, user or operator.

3.22 Load diagram: A notice displayed on the work platform showing the permitted number of persons and the weight and distribution of materials for the particular configuration.

3.23 Main platform: That part of the work platform which is built up using primary structural elements.

3.24 Manual of Responsibilities: A document containing the definitions (Section 3) and the requirements mandated in this Standard for the following entities: Dealers (Section 7.3); Owners (Section 7.4); Users (Section 7.5); Operators (Section 7.6); Lessors (Section 7.7); Lessees (Section 7.8); and Brokers (Section 7.9).

3.25 Manufacturer: A person or entity who makes, builds or produces a MCWP.

3.26 Mast: A structure that supports and guides the platform.

3.27 Mast, fixed length: A mast whose length is fixed and cannot be varied, even by the attachment of further mast sections.

3.28 Mast, variable length: A mast whose length can be varied by the attachment of successive lengths of prepared sections.

3.29 Mast tie: Anchorage system used to provide lateral restraint to the mast from the building or other structure.

3.30 Modification, modified: To make a change(s) to a MCWP which affects the operation, stability, safety factors, or rated load of the MCWP in any way.

3.31 Multilevel work platforms: Two or more work platforms travelling on the same mast or an additional working level attached to and totally supported by a work platform. (For illustration see annex B)

3.32 Operator: An authorized person qualified to control the movement of a MCWP.

3.33 Outrigger: Support at the base frame level used to maintain or increase the stability of the MCWP within specified conditions. An outrigger may also be used for leveling.

3.34 Outrigger beam: That part of an outrigger assembly which moves in a substantially horizontal plane and may be powered or operated manually.

3.35 Overspeed: Any speed above rated speed.

3.36 Overspeed detector: A device which, when the work platform attains a predetermined speed above rated speed, causes the overspeed safety device to be applied.

3.37 Overspeed safety device: A mechanical device for stopping and maintaining the work platform stationary on the mast in the event of overspeed

3.38 Owner: A person or entity who has possession of a MCWP by virtue has of proof of purchase or legal possession of a MCWP.

3.39 Planking (decking): A work surface used on platform extensions.

3.40 Platform extensions: Those additional parts of the work platform which are built up using secondary structural elements, whose support and location is dependent upon the main platform. They are used to extend the main work platform, usually along its longitudinal working edge. They may form irregular shapes, which conform, to the work site. They may also extend at a level just above or below the main platform level.

3.41 Platform height: The vertical distance measured from the floor of the platform to the surface upon which the MCWP is being supported.

3.42 Qualified person: One who, by possession of a recognized degree, certificate or professional standing, or who by extensive knowledge, training, and experience, has successfully demonstrated the ability to solve or resolve problems relating to the subject matter, the work, or the project.

3.43 Rack & pinion drive system: A drive system using a gearing arrangement consisting of a cylindrical gear (pinion) which engages a linear gear (rack) attached to the mast.

3.44 Rail mounted chassis: A chassis designed to transmit horizontal as well as vertical forces to the ground via rails.

3.45 Ratchet drive system: A drive system that operates by attaching a ratcheting device to the rungs or other element of the mast in an alternating manner and elevates or lowers the platform a predefined distance. The platform may be supported by a pawl or similar device when the drive mechanism is not engaged.

3.46 Rated load: The loads for which the MCWP has been designed for in normal operation as stated in the load diagram.

3.47 Rated speed: The vertical or horizontal speed for which the MCWP has been designed.

3.48 Remanufacture: The modification of a MCWP, either by the original manufacturer or an entity authorized by the manufacturer, so that the MCWP will comply with the ANSI Standard in effect on the date the modification is completed.

3.49 Re-rent: A transaction in which an entity not owning the MCWP benefits in some manner by arranging its utilization by a user.

3.50 Screw drive system: A drive system which consists of a mast mounted rack which meshes with a powered drive screw attached to the platform. Rotation of the powered drive screw elevates or lowers the platform.

3.51 Shall: The word shall is to be understood as mandatory.

3.52 Stability: A condition in which the sum of the moments which tend to overturn the MCWP is less than the sum of the moments tending to resist overturning.

3.53 Transfer: Any horizontal movement of the MCWP from one position to another on the same working site.

3.54 Transfer condition: The configuration of the MCWP in which it is moved from one position to another on the same working site.

3.55 Transfer and transport interlocks: Any design features on the MCWP which prevent unsafe transfer or transportation.

3.56 Transfer and transport loads and forces: Inertia forces plus any loads permitted by the manufacturer on the MCWP shall be taken into account when the MCWP is subject to transfer conditions. Including any limitation on the weather and the load or persons on the MCWP.

3.57 Transport: Any movement of the MCWP outside the boundaries of the working site.

3.58 Transport condition: The configuration of the MCWP in which it is moved outside the boundaries of the working site (for example road transport).

3.59 User: A person or entity that has care, custody and control of the MCWP. This person or entity may also be the employee of the operator, a dealer, owner, lessor, lessee, broker or the operator.

3.60 Upper & lower limit devices: Means to limit the maximum and minimum platform height, usually by mechanical or electrical means, or both.

mast ties, base and chassis. The work platform includes the main platform and any platform extension.

3.61 Work platform: The vertical traveling part of the installation upon which the persons, equipment and materials are carried and from which work is carried out. This is as opposed to the MCWP, which refers to the whole of the installation, including the work platform, mast,

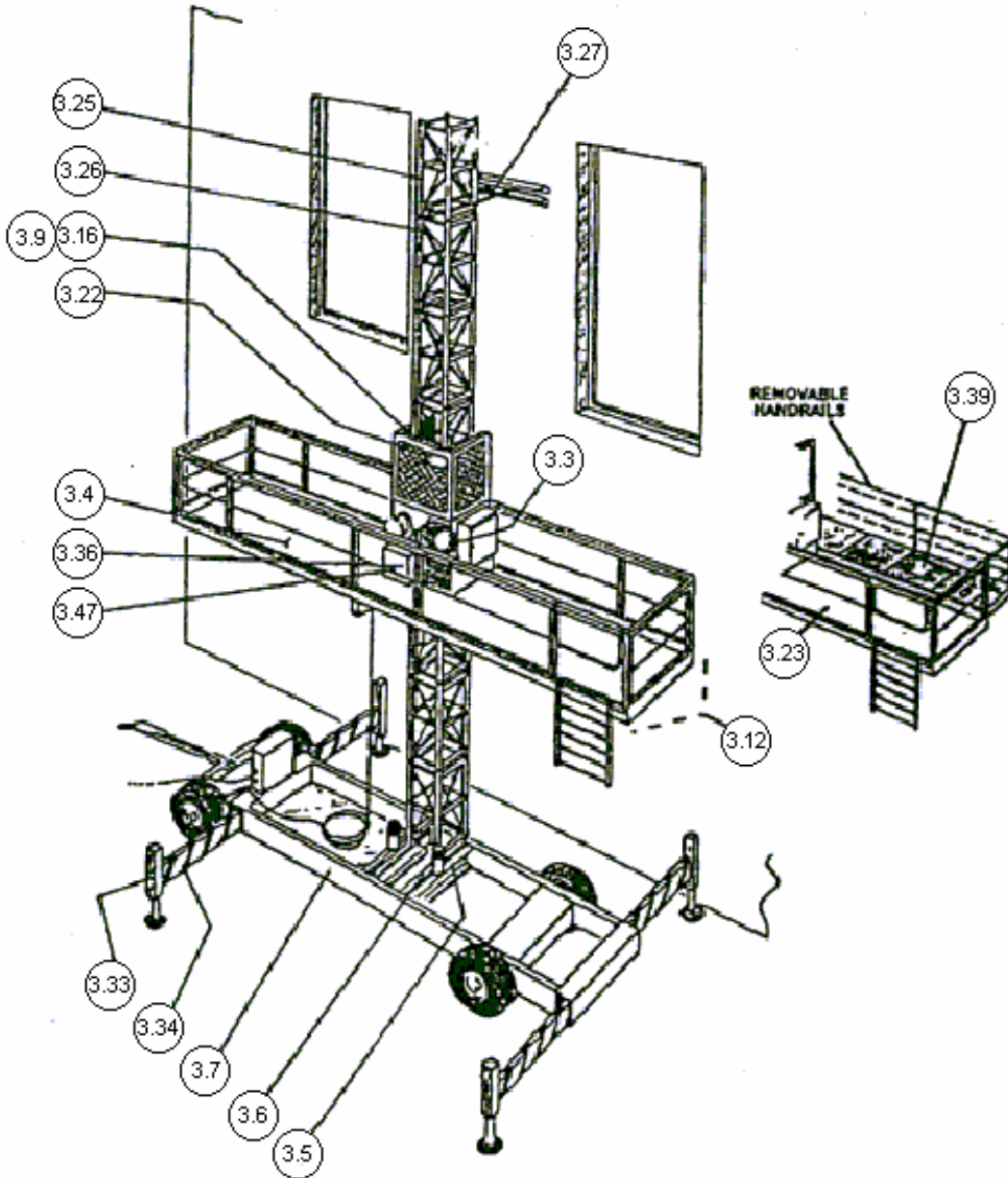

Figure 1: TYPICAL SINGLE MAST MCWP

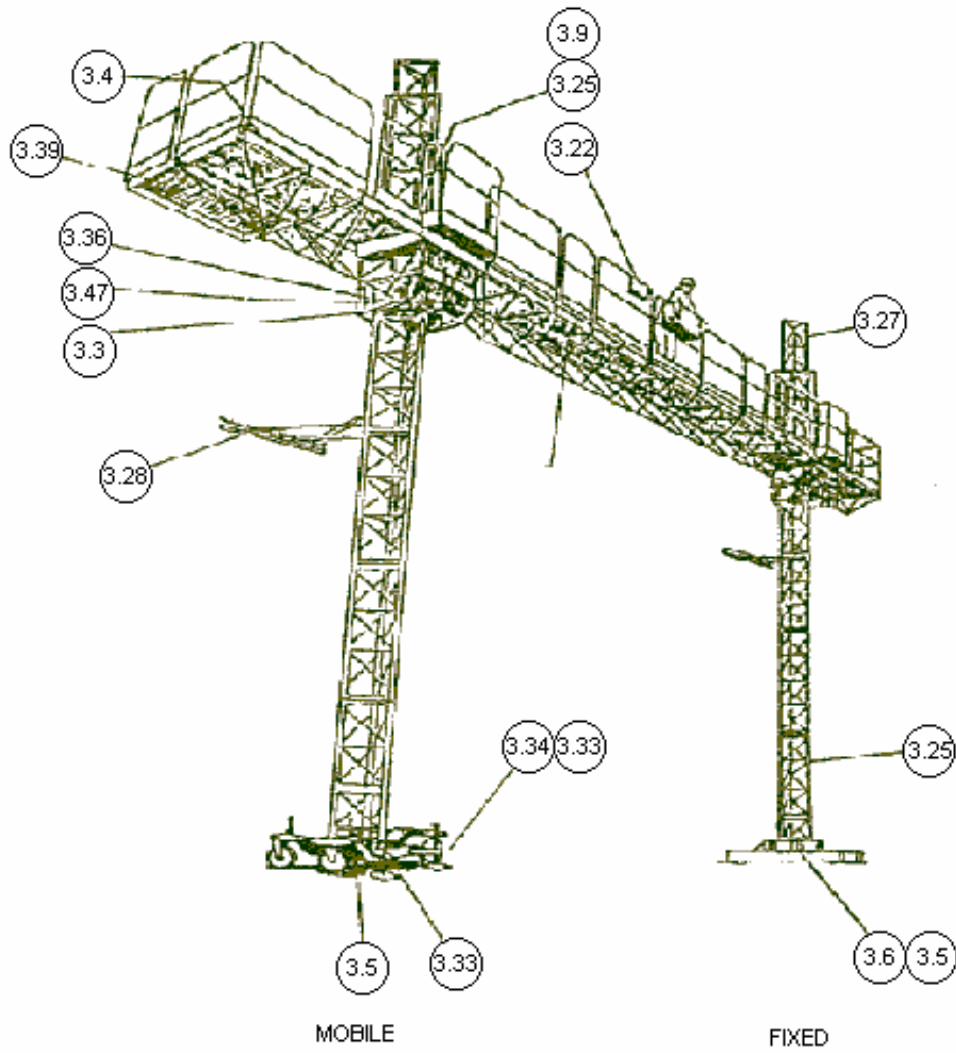

Figure 2: TYPICAL TWIN MAST MCWP

SECTION 4 - LIST OF HAZARDS

The following table shows the hazards which have been identified and where the corresponding requirements have been formulated in this standard in order to limit the risk or reduce these hazards in each situation.

A hazard which is not applicable or is not significant and for which, therefore, no requirements are formulated is shown in the relevant clause column as NA (not applicable).

Table 1

Hazards	Description	Relevant clauses in this Standard
1	Mechanical Hazards	
1.1	Crushing	5.2.1.3; 5.3.2; 5.4.1
1.2	Shearing	5.2.1.3; 5.3.2; 5.4.1
1.3	Cutting or severing	5.3.2; 5.4.1
1.4	Entanglement	5.4.1
1.5	Drawing in or trapping	5.2.1.3; 5.3.2; 5.4.1
1.6	Impact	5.4
1.7	Stabbing or puncture	NA
1.8	Friction or abrasion	NA
1.9	High pressure fluid ejection	5.10
1.10	Ejection of parts	5.2.1.4; 5.2.1.5
1.11	Loss of stability	5.1.5; 5.2; 5.2.5
1.12	Slip, trip and fall	5.3.1.3
2	Electrical Hazards	
2.1	Electrical contact	5.8; 7.1.2.7
2.2	Electrostatic phenomena	NA
2.3	Thermal radiation	NA
3	Hazards generated by materials and substances processed, used or exhausted by machinery	
3.1	Contact with or inhalation of harmful fluids, gases, mists, fumes and dusts	5.9; 5.10
3.2	Fire or explosion	5.9; 5.10
3.3	Biological and microbiological	5.9; 5.10
4	Hazards generated by neglecting ergonomic principles in machine design	
4.1	Unhealthy postures or excessive effort	5.2.1.6; 5.2.5.2; 5.6.2; 5.12
4.2	Inadequate consideration of human hand/arm or foot/leg anatomy	NA
4.3	Neglected use of personal protection equipment related measures/means	7.1.2.7; 7.1.2.12
4.4	Inadequate area lighting	7.1.2.6
4.5	Mental overload or underload, stress	NA
4.6	Human error	5.2.2.1; 5.12

5		Hazard combinations	5.1.1.1; 5.1.1.2; 5.1.3; 5.2.1.3; 5.7.1.7; 5.1.2.9; 7.1.2.12; 7.5.9; 7.6.7; 7.6.8
6		Hazards caused by failure of energy supply, breaking down of machinery parts and other functional disorders	
	6.1	Failure of energy supply	5.4.1.7; 5.4.4.2.1; 5.5; 5.7.1.6; 5.8; 5.10.1
	6.2	Unexpected ejection of machine parts or fluids	5.4.1.2; 5.9.1; 5.9.5; 5.10
	6.3	Failure or malfunction of control system	5.4.4.2.1; 5.4.5.1.1; 5.5.1.1; 5.5.2.2.1; 5.5.3; 5.6.1; 5.7; 5.8; 5.11; 5.12; 5.13.5; 6.1.2.2.2
	6.4	Errors of lifting	5.1.2.11; 5.1.5.1.5; 5.2.4; 5.4
	6.5	Overturn, unexpected loss of machine stability	5.1.1.2; 5.1.2.3; 5.1.2.5; 5.1.2.11; 5.1.3; 5.1.5; 5.2.1.4; 5.2.2.2; 5.2.2.3; 5.2.5.1; 5.4.1.6; 5.2.1.6
7		Hazards caused by missing and/or incorrectly positioned safety related measures and means	
	7.1	Guards	5.2.1.3; 5.3.2; 5.4.1.2; 7.1.2.6; 7.1.2.9; 7.2.2
	7.2	Safety related (protection) devices	5.2.1.2; 5.2.1.4; 5.2.1.5; 5.4.4.2; 5.6
8		Inadequate lighting of moving / working area	7.1.2.6
9		Hazards due to sudden movement instability etc. during handling	5.1.5; 5.2.2
10		Inadequate / non ergonomic design of operating position	
	10.1	Hazards due to dangerous environments (contact with moving parts, exhaust, gases, etc.)	5.2.2; 5.9; 5.3.1.3; 5.3.2; 5.3.3
	10.2	Inadequate visibility from operators position	5.12.2; 5.12.5
	10.3	Inadequate seat/seating	NA
	10.4	Inadequate/non ergonomic design/positioning of controls	5.12
	10.5	Start/moving of self propelled machinery	5.12; 5.13
	10.6	Road traffic of self propelled machinery	7.1.2.6; 7.1.2.12
	10.7	Movement of pedestrian controlled machinery	7.1.2.6; 7.1.2.12
11		Mechanical hazards	
	11.1	Hazards to exposed persons due to uncontrolled movement	5.2.2.1; 5.2.4; 5.4.1; 7.1.2.7
	11.2	Hazards due to breakup and/or ejection of parts	5.2.1.4; 5.2.1.5; 5.2.2.3
	11.3	Hazards due to rolling over (ROPS)	5.1.5
	11.4	Hazards due to falling objects (FOPS)	7.1.2.7
	11.5	Inadequate means of access	5.3.3; 5.3.3.4

	11.6	Hazards due to towing, coupling, connecting, transmissions, etc.	5.4.1; 7.1.2.7; 5.2.2.4
	11.7	Hazards due to batteries, fire, emissions, etc.	5.9.1; 5.9.2; 5.9.3; 5.9.4; 5.9.5; 5.9.6
12		Hazards due to lifting operations	
		Lack of stability	5.1.5; 5.1.1.2; 5.2.2.3; 5.2.2.2; 5.2.5.1; 5.4.1.6
		Derailment of machinery	7.2.2.4; 7.4.1.5; 5.4.2; 5.4.1.5; 5.12.2
		Loss of mechanical strength of machinery and lifting accessories	5.1; 5.2.1.7; 5.2.1.8; 5.2.2.2; 5.2.2.3; 5.2.3.3; 5.2.5.3; 5.3.1.4; 5.4.2; 5.4
		Hazards caused by uncontrolled movement	5.2.2.3; 5.2.4; 5.4.1; 5.11; 5.2.5; 5.10.12.3
13		Inadequate view of trajectories of moving parts	5.13.4
14		Hazards caused by lightning	7.1.2.6 g)
15		Hazards due to loading/overloading	5.5.2.2
16		Overloading or overcrowding of the platform	5.1.2; 5.5.2.2; 5.5.3
17		Unexpected movement of the platform in response to external controls	5.12.2; 5.8
18		Excess speed	5.5; 5.6.3; 5.4.4.1; 3.5.3
19		Persons falling from the platforms	5.3.2
20		The platform falling or overturning	5.2.2.3; 5.5; 5.10; 5.2.3; 5.2.5
21		Excess acceleration or braking of the platform	5.5; 6.4.4.4.2.2; 5.4.5
22		Due to imprecise markings	5.2.2.5

SECTION 5 - SAFETY REQUIREMENTS AND/OR MEASURES

5.1 Structural and stability calculations

5.1.1 General

Sound engineering principles consistent with all data available regarding the parameters of intended use and expected environment shall be applied in the design, testing and manufacture of MCWP's, with due consideration of the knowledge that the unit will be carrying personnel.

5.1.1.1

All loads and forces which can occur in any allowed configuration during erection, operation, out-of-service, dismantling and transfer shall be considered. This shall also include inclined or hanging masts.

5.1.1.2

The manufacturer shall be responsible for:

- a) stability calculations, in order to identify the various configurations of the MCWP and the combinations of loads and deflections, which together create conditions of instability
- b) structural calculations, in order to evaluate the individual forces and to make allowance for deflections. All combinations of forces shall be considered including those which produce the most unfavorable stresses in the components.

5.1.2 Loads and Forces

The following loads and forces shall be taken into account.

5.1.2.1 Structural loads

The masses of the components of the MCWP when they are not moving are considered to be static structural loads.

The masses of the components of the MCWP when they are moving are considered to be dynamic structural loads.

5.1.2.2 Rated load

5.1.2.2.1 The rated load for design purposes is:

$$m = (n \times m_p) + m_t + (2 \times m_e)$$

where m	=	rated load (lbs)
m_p	=	175 lbs (80 kg); mass of each person
m_e	=	90 lbs (40kg); mass of personal equipment (for the first two persons only)
m_t	=	mass (lbs.) of material and equipment on the work platform (excluding personal equipment)
n	=	number of persons on the work platform

The mass of persons and the mass of equipment and material shall act simultaneously.

The minimum number of persons shall be: Two (2) for single mast platforms and four (4) for multiple mast platforms.

The mass of the personal equipment (m_e) shall be assumed to act on the point coincident with each of the two persons which give the highest stresses.

5.1.2.2.2

The mass of each person is assumed to act as a point load on the MCWP at a horizontal distance 4 in (0.1 m) from the upper inside edge of the top guard rail. The distance between the point loads shall be 20 in (0.51 m) (see figure 3 as an example).

5.1.2.2.3

The mass m_t shall be evenly distributed over the entire area of the main platform giving a specific load per length t .

The center of gravity of the mass m_t shall be assumed to act on a point 0.15 B (where B is the width of the main platform) away from the longitudinal center line of the main platform, on the side giving the highest stresses. See figure 4.

Calculations shall allow for the possibility that a reduced load giving an unbalanced loadcase may result in higher stresses in some parts of the MCWP than a balanced rated load case would give.

For single mast machines the bending moment, M , on masts and platforms shall be calculated according to Formula 1, where L_{\max} is the greater of the distances L_1 and L_2 in figure 5.

For multiple mast machines the bending moment M , on masts and platforms shall be calculated according to Formulas 2, 3, 4 and Figure 6. The factors 1.15 and 1.2 are used in the Formulas 1, 2, 3, 4 in order to cover the situations in use where, instead of a uniformly distributed load, a concentration of the same load is placed elsewhere within that individual length.

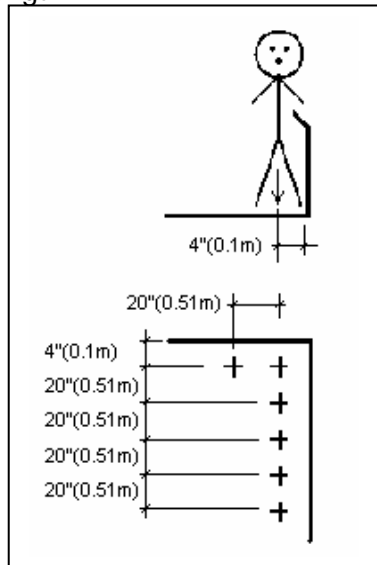

Figure 3: Example of the distribution of persons on the main platform or platform extensions.

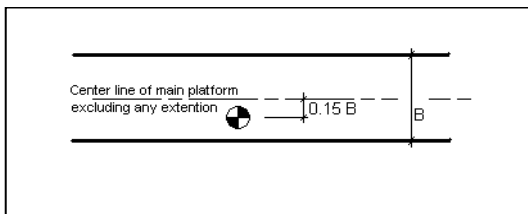
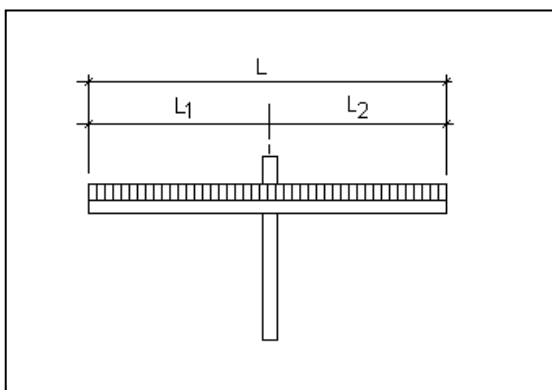

Figure 4: Eccentric loading normal to the centerline.



Formula (1)
$$M_{max} = \frac{t \times L_{max}^2}{2} \times 1.15$$

Figure 5: Loading in the longitudinal direction. Single mast machines.

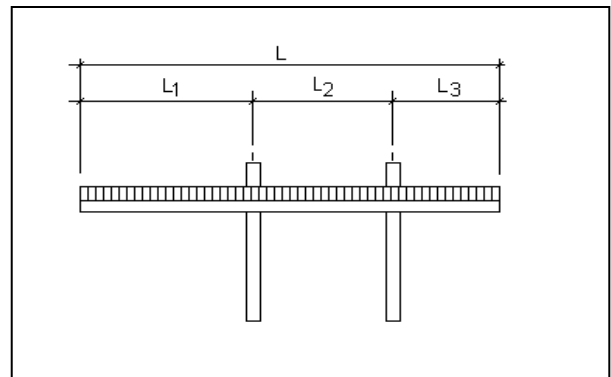

Figure 6: Loading in the longitudinal direction. Multiple mast machines.

Formulas: (2):
$$M_1 = \frac{t \times L_1^2}{2} \times 1.15$$

(3):
$$M_2 = \frac{t \times L_2^2}{2} \times 1.2$$

(4):
$$M_3 = \frac{t \times L_3^2}{2} \times 1.15$$

5.1.2.2.4

If the area of the main platform, or part of it, is increased by means of extensions, usually to the longitudinal edge of the platform, the mass of the number of persons allowed on the platform, according to 5.1.2.2.1, shall be assumed to act on these longitudinal edges according to 5.1.2.2.2.

5.1.2.2.5

In order to provide long cantilever extensions to reach more distant work points an exception to 5.1.2.2.4 may be made, but shall be clearly explained on a sign easily visible on that particular extension to the main platform. In no such case shall the load on the extension be calculated for less than two persons (m_p) carrying their personal equipment (m_e). In order to restrict the available platform extension area, such extensions shall not be more than 24 in (0.6 m) wide. See Figure 7.

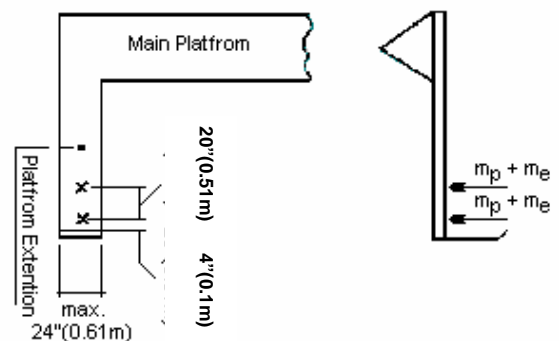

5.1.2.2.6

When a handling crane is installed on the platform the mass of the crane and the cranes rated load shall together be treated as part of the rated load of the MCWP. The location of the force resulting from the use of the crane shall be dictated by the manufacturers chosen mounting positions for the crane supports.

5.1.2.3 Horizontal forces

5.1.2.3.1 Manual forces

The minimum value for the manual force is assumed to be 45 lbf (200 N) for each of the first two persons on the platform and 22.5 lbf (100 N) for each additional person permitted on the work platform.

It is assumed that the force is applied at a height of 42-in (1.1 m) above the floor of the work platform and acts in a horizontal direction.

5.1.2.3.2 Forces from the use of power tools

Where the manufacturer of the MCWP permits the use of power tools which impose horizontal reaction forces on the work platform which are in excess of those given in 5.1.2.3.1 then the manufacturer shall specify the maximum force permitted. It is to be assumed that the force is applied at a minimum height of 42 in (1.1 m) above the floor of the work platform.

Such forces may be caused by the use of, for example:

- water jetting equipment
- sand or grit blasting equipment
- mechanically assisted drilling machine
- hammer assisted drill
- electrically driven hammer/breaker

5.1.2.3.3 Forces from the use of weather protection screens on the Work Platform

If the Work Platform is designed to permit the use of weather protection, in the form of a roof over part of, or the whole of the platform, then the resulting wind forces shall be considered to act on walls which reach the full height from the work platform floor to the top of the roof. Wind forces shall be calculated according to 5.1.2.5 and 5.1.2.8. For platform regions protected by such weather screens, the wind forces on persons, equipment and material coming under the protection of these weather screens may be neglected.

The mass of the weather protection screens shall be treated as part of the rated load.

5.1.2.4 Dynamic forces

Dynamic forces shall be taken into account by multiplying all moving masses by a dynamic factor of 1.15.

The term, moving, includes raising and lowering of the work platform and also transfer of the MCWP in its transfer condition.

5.1.2.5 In service wind loads

5.1.2.5.1

All MCWP used out-of-doors or otherwise exposed to wind, while in service, shall be regarded as being affected by a minimum wind pressure in accordance with table 2.

5.1.2.5.2

Wind forces are assumed to act horizontally at the center of the windward area of the exposed structural parts of the MCWP.

5.1.2.5.3

The wind-force coefficients applied to areas exposed to the wind and calculation of wind

Table 2: Minimum design wind data for in-service conditions

Installation	Wind velocity Mph [m/s]	Wind pressure Psi [N/m ²]
Freestanding or MCWP during erection and dismantling.	28 [12.7]	0.0145 [100]
Tied MCWP	35 [15.5]	0.0218 [150]

Note: The wind values given in Table 3 are minimum values for the central United States area and at low altitudes. In special cases, e.g. coastal areas or at higher altitudes, information set out in the ANSI/ASCE 7-02 national standard shall be used.

forces shall be in accordance with ANSI/ASCE 7-02. The wind-force coefficient for persons exposed to the wind is 1.0.

5.1.2.5.4

The full area of one person is 7.53 ft² (0.7 m²) [15.7 in (0.4 m) average width x 69 in (1.75 m) height] with the center of area 39.4 in (1.0 m) above the work platform floor.

5.1.2.5.5

The exposed area of one person standing on a work platform behind an unperforated section of fencing 43 in (1.1 m) high is 3.76 ft² (0.35 m²) with the center of area 4.75 ft (1.45 m) above the work platform floor.

5.1.2.5.6

The number of persons directly exposed to the wind is calculated as:

- a) The length of the side of the work platform exposed to the wind, rounded to the nearest 20 in (0.5 m) and divided by 20 in (0.5 m), or
- b) The number of persons allowed on the work platform if less than the number calculated in a).

5.1.2.5.7

If the number of persons permitted on the work platform is greater than in 5.1.2.5.6 a), a reducing coefficient of 0.6 may be applied to the extra number of persons.

5.1.2. 5.8

The wind force on exposed equipment and material on the work platform is, calculated as 3 % of the mass **T**, acting horizontally at a height of 39.4 in (1.0 m) above the work platform

floor.

5.1.2.6 Loads and forces occurring during transfer conditions

Inertia forces plus any load permitted by the manufacturer on the work platform shall be taken into account when the MCWP is subject to transfer conditions.

5.1.2.7 Erection and dismantling loads

Loads imposed during erection and dismantle shall be considered in the MCWP design. If the handling crane, on the platform as referred to in 5.1.2.2.6, is used during erection and dismantling of the MCWP then the mass of the crane and the cranes rated load shall together be treated as part of the erection and dismantling load.

5.1.2.8 Out-of-service wind loads

While out of service, with the work platform in a safe position, the wind pressure for the calculations shall be in accordance with table 3. The limiting wind pressure shall be considered in the most unfavorable direction.

5.1.2.9 Buffer forces

Buffer forces shall be calculated taking into account the characteristics of the buffer according to 5.4.6. Where buffers are not used, deceleration or impact forces shall be taken into account in the design.

5.1.2.10 Action of the safety means according to 5.5

Table 3: Minimum design wind data out-of-service conditions

Height of member Above ground level ft [m]	Wind velocity Mph [m/s]	Wind pressure Psi [N/m ²]
0 to 66 [0 to 20]	80 [35.8]	0.116 [800]
over 66 to 330 [20 to 100]	94 [42]	0.160 [1100]
over 330 [over 100]	103 [45.9]	0.189 [1300]

Note: The wind values given in Table 3 are minimum values for the central United States area and at low altitudes. In special cases, e.g. coastal areas or at higher altitudes, information set out in the ANSI/ASCE 7-02 national standard shall be used.

To determine the forces produced by an operation of these means, the sum total of all travelling masses shall be multiplied by a factor of 2. A lower factor, but not less than 1.2, may be used if it can be verified by test under all conditions of loading up to 1.5 times the rated load.

5.1.2.11 Mast erection tolerances

For the purposes of calculation an allowance of an additional 0.5⁰ shall be made to allow for user inaccuracy when erecting the mast.

5.1.3 Load combinations and safety factors

The load combinations to be taken into consideration shall be as follows:

Load combination A1:
MCWP in service without wind, static

Load combination A2:
MCWP in service without wind, dynamic.

Load combination B1
MCWP in service with wind, static.

Load combination B2:
MCWP in service with wind, dynamic.

Load combination B3
MCWP during erection or dismantling

Load combination B4:
MCWP during transfer condition

Load combination C1:
MCWP striking the buffer while in service

Load combination C2:
MCWP during action of the safety means while in service.

Load combination C3:
MCWP out of service.

The above load combination references (A1, A2, B1, B2 etc) are used in Annex A (informative) as load case A, load case B and load case C as appropriate.

In each load combination the loads and forces acting on the MCWP shall be in accordance with table 4. Safety factors for structural steels and aluminum alloys are given in Table 5 and Table 6 respectively.

Load combination

Loads	Ref. clause	A1	A2	B1	B2	B3	B4	C1	C2	C3
Structural loads	5.1.2.1	X	X	X	X	X	X	X	X	X
Rated load	5.1.2.2	X	X	X	X			X	X	
Horizontal forces	5.1.2.3	X		X						
Dynamic forces	5.1.2.4		X		X	X	X			
In service wind loads	5.1.2.5			X	X	X	X			
Loads and forces during transfer condition	5.1.2.6					X	X			
Erection and dismantling loads	5.1.2.7					X				
Out of service wind loads	5.1.2.8									X
Buffer forces	5.1.2.9							X		
Action of safety means	5.1.2.10								X	
Inaccuracies in setting up	5.1.2.11	X	X	X	X	X	X			

Table 4: Load Combinations that shall be taken into consideration

Load case	Safety factor
A1, A2	1.5
B1, B2, B3, B4	1.33
C1, C2, C3	1.25

Table 5: Safety factors for structural steels

Load case	Safety factor
A1, A2	1.7
B1, B2, B3, B4	1.55
C1, C2, C3	1.4

Table 6: Safety factors for structural aluminum alloys

5.1.4 Structural calculations

See the following:

Annex A (Informative)

AISC Allowable Stress Design

AISC Load Resistance Factor Design

5.1.5 Stability calculations

5.1.5.1 Calculation of forces

5.1.5.1.1

Forces causing overturning moments shall, when created by structural masses, be multiplied by a factor of 1.1 and when created by rated loads be multiplied by a factor of 1.2. It must be remembered here that an inclination of the mast from the vertical will result in an increasing overturning moment as the work platform travels upwards.

All forces causing stabilizing moments shall be multiplied by a factor of 1.0.

5.1.5.1.2

Wind forces shall be multiplied by a factor of 1.2 and assumed to be acting horizontally.

5.1.5.1.3

Horizontal forces as detailed in clause 5.1.2.3 shall be multiplied by a factor of 1.2 and assumed to be acting in the direction creating the greatest overturning moment.

5.1.5.1.4

Forces according to 5.1.2.6 shall be treated in the same way as specified in 5.1.5.1.1, 5.1.5.1.2 and 5.1.5.1.3 as appropriate.

5.1.5.1.5

Inaccuracies in setting-up according to 5.1.2.11 shall be taken into account in the stability calculation.

5.1.5.2 Calculation of overturning and stabilizing moment

The maximum overturning and corresponding stabilizing moments shall be calculated about the most unfavorable tipping lines.

The calculations shall be made with the MCWP in the most unfavorable configurations with the maximum allowable inclination of the chassis defined by the manufacturer. Every load and force combination including inaccuracy in setting-up shall be taken into account in their most unfavorable combinations.

In each case the calculated stabilizing moment shall be greater than the calculated overturning moment.

5.2 General machine requirements, base frame, chassis and mast

5.2.1 General machine requirements

5.2.1.1

The MCWP and all parts belonging to it shall be calculated in accordance with 5.1.

5.2.1.2

MCWP shall be equipped with a permanently installed device on the work platform to switch off the work platform and secure it against unauthorized use while out-of-service.

Similar devices shall be permanently installed at the chassis of self propelled MCWP which isolates all movements of the MCWP.

Such devices shall be secured by a pad-lock or similar device.

5.2.1.3

Trapping and shearing points between the chassis and work platform shall be avoided by providing safe clearances or adequate guarding.

If safe clearance or adequate guarding, is not possible, then an acoustic warning device shall be fitted to the work platform which at least gives a continuous warning when the work platform is moving within 8.2 ft (2.5 m) of the chassis.

Trapping, crushing and shearing points need only be considered at those areas within reach of persons on the work platform or standing adjacent to the MCWP at ground level, or at other points of access.

5.2.1.4

Locking pins shall be designed to be mechanically secured against unintentional disengagement and loss while in use, i.e. split pin, locking nut, etc.

5.2.1.5

Where compression springs are used for a safety function they shall be guided with secured ends. Their design shall be such that if they break then the parts cannot coil into each other.

5.2.1.6

The design of all components that have to be handled during erection i.e. mast section, platform components, erection cranes, shall have their weight assessed against manual handling. Where the permissible weight for normal handling, is exceeded, the manufacturer shall give recommendations in the instruction handbook concerning suitable lifting equipment.

5.2.1.7 Attachment of lifting equipment

Where components are erected by means of lifting equipment, provision shall be made for adequate attachment of the lifting equipment. This shall ensure that the component is securely attached and lifted in the correct position for assembly.

5.2.1.8 Lifting equipment

Any dedicated lifting equipment shall not impose loads on the MCWP structure for which the MCWP was not designed.

5.2.2 Base frame and chassis**5.2.2.1 General**

If chains or belts are used in drive systems, inadvertent movements of the chassis shall be automatically prevented if failure of a chain or belt occurs.

If powered and manual drive systems are provided for the same movement, interlocks shall prevent both systems from being engaged at the same time.

After failure of the power supply, no inadvertent movement shall occur.

Walkways on the base frame or chassis shall be equipped with a slip resistant surface.

5.2.2.2 Base frame

The base frame shall be equipped with fixings for safe and secure attachment of other parts of the construction such as mast and outriggers.

5.2.2.3 Chassis

The chassis shall be equipped with fixings for safe and secure attachment of other parts of the construction such as mast and outriggers.

Means shall be provided to ensure, or at least to give proper warning, that the MCWP is in the proper transfer (or transport) condition.

If the platform must be locked at a position on the chassis during transport, then transport interlocks shall be provided.

Means shall be provided to prevent instability of the MCWP due to failure of any tire of the chassis, for example by the provision of foam filled tires or by giving instructions in the user manual regarding use of outriggers.

5.2.2.4 Drive to wheels (excluding road transport)

The chassis shall be capable of being stopped and held stationary with a braking device under all ground conditions and also the worst combination of horizontal speed and maximum gradient specified by the manufacturer. The brakes shall only be released and kept released by an intended action. Under all other conditions the brake shall apply automatically. After being applied the means of braking shall not depend on an exhaustible energy source. Acceleration and retardation must be within the manufacturer's stability criteria. It shall be possible to disengage the drive to the wheels before towing the MCWP.

For rail mounted chassis, means shall be provided to stop the machine safely at the limits of travel.

If axles are detachable, the chassis shall be equipped with fixings for safe and secure attachment of the axles when they are in use.

5.2.2.5 Outriggers

Outriggers shall be capable of carrying all loads permitted by the manufacturer. Max. allowable inclination and operation on the max. gradient permitted by the, manufacturer shall also be considered.

The feet of the outriggers shall be designed to swivel in all directions by an amount equal to the maximum gradient specified by the manufacturer plus at least 10⁰.

Refer to the instruction manual for information on the applied ground pressure resulting from the outrigger feet.

Movement of the outrigger beams shall be limited by mechanical stops. It shall also be possible to lock them at least in their extreme positions.

The outriggers shall be designed and manufactured so that unintentional movement is prevented.

Any hydraulic outrigger shall be equipped with a load holding valve, mounted directly to the cylinder. This valve, i.e. a pilot operated check valve or brake valve, shall prevent unintended flow of oil to or from the cylinder, even in case of pipe or hose rupture.

The closing of this valve shall not cause a dangerous situation.

Power operated outriggers shall be fitted with a device to prevent power operated movement of

the outriggers, unless the work platform is in its intended position.

Outriggers relying on a permanent pneumatic pressure to provide support during use of the platform shall not be used.

Where central supports are provided directly beneath the masts these shall also comply with the relevant requirements of this clause.

5.2.2.6 Tow-bar

Tow-bar and steering mechanisms shall be designed to minimize handling hazards to the user.

5.2.2.7 Warning marks

Outriggers, outrigger beams and other parts of the base frame or chassis protruding from the main outline of the platform shall be marked with warning colors.

5.2.3 Mast structure

5.2.3.1 General

Structural components of the mast required for the drive system of the elevating assembly (eg rack, drive tracks, rungs, etc.) shall be visible for detailed examination without dismantling.

5.2.3.2 Racks and similar devices

The racks and similar devices shall be securely attached to the mast. Joints between adjacent sections of the rack shall be accurately aligned to avoid faulty meshing or damage to teeth or similar components.

5.2.3.3 Tie attachment points

If the MCWP is to be tied into a separate supporting structure the mast sections shall be designed to accommodate the attachment of ties at appropriate intervals. Attachment points shall be designed in accordance with 5.1.

5.2.3.4 Marking

All mast sections shall be marked with a lot number, a mark or symbol enabling the date of manufacture to be determined.

5.2.4 Mast design with regard to erection

Effective means shall be provided to ensure, so far as practical, that only correctly interchangeable mast sections can be connected together.

The design of the mast shall ensure effective load transfer between adjacent mast sections and that alignment is maintained.

Where the vertical members of the mast sections are used as guides for drive frame guide rollers the joints of adjacent sections shall provide a continuous path.

MCWP with masts which are tilted to the working position for use shall be equipped with a device to ensure that the mast is mechanically locked in the working position automatically. It shall not be possible to raise the work platform unless this lock is engaged.

5.2.5 Mast ties

5.2.5.1 General

MCWP's will require lateral restraint from an adjoining separate supporting structure when erected above the manufacturer's specified maximum free standing height. This restraint will normally be in the form of mast ties attached at intervals between the mast and the supporting structure.

5.2.5.2 Design

Mast ties shall be designed for manual handling and ease of assembly using hand tools and shall provide a degree of adjustment to accommodate tolerances between the mast and the supporting structure. They shall provide sufficient torsional rigidity to the mast.

5.2.5.3 Attachment to the supporting structure

The attachment of the mast ties to the supporting structure shall be designed to resist all forces generated, both in and out of service. Sufficient information shall be provided in the instruction handbook to enable the forces applied to the supporting structure to be calculated.

5.3 Work platform

5.3.1 General

5.3.1.1

The work platform shall remain in a horizontal position within $\pm 2^{\circ}$ during normal movements of the platform and under the application of the rated load and other forces exerted during normal operation. During operation of the means described in 5.5 and the emergency

lowering/raising device in 5.6 the max permitted variation from horizontal shall be $\pm 5^{\circ}$.

5.3.1.2

Trapdoors in the work platform shall be securely fastened and shall not open downwards.

5.3.1.3

The floor material shall be slip-resistant. The floor shall be easy to clean and shall be self draining. Any opening in the floor or between the floor and toeboards or access gates shall be dimensioned so as to prevent the passage of a sphere of 5/8 in (15 mm) diameter. The floor material shall be securely fixed to the work platform. Any extensions shall be prepared for fixing of the floor material.

5.3.1.4

The main platform floor shall be designed to withstand without permanent deformation a static load of at least 440 lbs (200 kg) exerted on the least favorable square area of 4 in x 4 in (0.1 m x 0.1 m).

5.3.1.5

Any platform extensions of the main platform shall be able to be secured to prevent their inadvertent movement. There shall be a clear indication of the maximum permitted extended position. The platform extension shall be designed to prevent it from being extended beyond its maximum permitted extended position.

5.3.1.6

Platform extensions shall not be more than 24 in (0.6 m) above or below the level of the main platform.

5.3.1.7

Planking (decking) shall follow the guideline set forth in OSHA regulations (29 CFR part 1926).

5.3.2 Guarding

5.3.2.1

All sides of the main platform and any platform extension shall be designed to be equipped with a guardrail which can be securely fastened in position.

5.3.2.2

Except for the cases given in 5.3.2.4 the guardrails shall be:

5.3.2.2.1 Top rail

The guardrail system shall include a top rail around the upper periphery of all exposed sides. The top rail shall be 42 in (1.06 m) high, plus or minus 3 in (76 mm), above the platform surface. Equivalent structure may be used in place of top rails, but shall meet the strength requirements of section 5.3.2.4 of this standard.

5.3.2.2.2 Mid rail

The guardrail system shall include a mid rail approximately midway between the top rail and the platform surface on all exposed sides. Equivalent structure may be used in place of mid rails, but shall meet the strength requirements of section 5.3.2.4 of this Standard.

5.3.2.2.3 Toeboards

The platform shall include toeboards on all exposed sides. The minimum toeboard height shall be 4 in (0.1 m). Toeboards; may not be omitted at the access opening(s). Toeboards shall withstand, without failure, an outward force of at least 50 lbs (23 kg).

5.3.2.2.4 Structural integrity

Each top rail, mid rail, or equivalent vertical barrier shall withstand without failure a force of 300 lbs (136 kg), applied at any point in an outward or downward direction without reaching ultimate strength.

5.3.2.3

It is to be noted that if the platform is erected towards a wall and the distance between the wall and platform is more than 14 in (0.36 m) a guardrail shall be required to prevent persons from falling between the wall and the platform (The maximum distance between the wall and platform shall increase to 18 in (0.46 m) for plastering and lathing operations.)

When it is possible to have a horizontal distance between the wall and platform of not more than 14 in (0.36 m) then a guardrail is not necessary. See 7.1.2.12.

5.3.2.4

Chains or ropes shall not be used as guardrails.

5.3.2.5

Where the movement or speed of the main platform and any extensions exceed 12 ft/min (0.06 m/s), or the clearance between the platform and the mast is less than 6 in (0.15 m), guarding shall be installed to a height of at least 6 ft 6 in (2.0 m) to prevent access to the mast.

5.3.2.6

Where the platform extension is not flush with the main platform, the unprotected opening between the two levels shall be guarded at least with a toeguard of 4 in (0.1 m) height located on the lower level.

5.3.3 Access**5.3.3.1**

At least one access gate shall be provided and it shall not open outwards. All access gates shall be so constructed as to either close automatically or be electrically interlocked to prevent operation of the work platform unless they are closed. Inadvertent opening of the access gate shall not be possible. Chains or ropes shall not be used as access gates.

5.3.3.2

When the distance between the access level and the floor of the work platform in the access position exceeds 24 in (0.61 m), the MCWP shall be equipped with an access ladder or stairs symmetrical with the access gate. The steps or rungs shall be divided equally over the distance between the access level and the floor of the work platform and in no case shall the step rise be more than 12 in (0.3 m).

The front of the steps or rungs shall be located to give at least 6 in (0.15 m) toe Clearance.

5.3.3.3

Handholds, handrails or similar adequate devices shall be provided to facilitate climbing the access ladder to the work platform.

5.3.4 Multilevel work platforms**5.3.4.1**

For multilevel work platforms the special requirements given in Annex B for options A and B shall be taken into account. In addition the following shall apply.

5.3.4.2

All additional components that are used with multilevel MCWP shall be calculated according to 5.1.

All additional forces imposed upon the main platform and the mast structure shall be calculated according to 5.1.

5.3.4.3

Guarding shall be in accordance with 5.3.2.

5.3.4.4

Roof protection shall be arranged for the lowest platform in option B to protect persons from falling objects.

The roof construction for the lowest platform shall:

- be designed to withstand a load of 220lbs (100 kg) distributed on any area 4 in (0.1m) x 4 in (0.1 m), and
- be designed so as to prevent the passage of a sphere of 5/8" (15 mm) diameter.

5.3.4.5

In option A the two work platforms shall not be separated by more than 9 ft – 10 in (3.0 m) between platform floor levels.

5.3.4.6

The separation distance between work platforms in option B shall be controlled by safety contact switches. This distance shall not be less than 8ft – 2 in (2.5 m) in normal operation taking into account leveling inaccuracies.

5.3.4.7

Ladders for option A shall comply with 5.3.3. Fixed access between the two work platforms shall be provided within the platform guarded area. Trapdoors shall comply with 5.3.1.2.

For option B direct access between work platforms shall not be provided.

5.3.4.8

For option A with multiple mast applications, platform leveling shall be in accordance with 5.3.1.1. The design shall ensure that clearance remains between the subsidiary work platform and the mast over the full leveling range.

5.3.4.9

Controls shall be in accordance with 5.12.

5.3.4.10

Buffers shall be in accordance with 5.4.4. For option A where the secondary work platform is located below the primary work platform, the height of the buffer shall be increased in order to act on the primary work platform.

5.3.4.11

For option A travel limit switches shall be in accordance with 5.11 taking into account the position of the secondary work platform.

For option B separate travel limit switches shall be provided for each work platform, all in accordance with 5.11 making allowance for the separation distance required in 5.3.4.6.

5.4 Drive systems for elevation**5.4.1 General****5.4.1.1**

The maximum rated speed when raising and lowering the platform shall be no more than 40 FPM (0.2 m/s).

5.4.1.2

Fixed guarding shall be provided to prevent the entry of any material that might cause damage to any part of the drive system and to protect persons from injury.

5.4.1.3

Chains or belts shall only be used in drive mechanisms in conjunction with an electrical or mechanical safety device which stops the work platform and keeps it stopped as soon as failure of a chain or belt occurs. The safety factor of the wire rope or chain system shall not be less than 8:1 based on ultimate strength.

5.4.1.4

Manual drive systems shall be designed and constructed to prevent kickback of handles.

5.4.1.5

Measures shall be taken to prevent the uppermost guide rollers or shoes running off the top of the guides during normal operation. Further measures shall be taken to ensure that under no circumstances, including erection and dismantling, can any safety device pinion come out of mesh with the rack or any mechanical

safety device designed to prevent uncontrolled descent become inoperative.

5.4.1.6

Measures shall be taken to ensure the continued stability of the work platform in the case of failure of any guide roller or shoe.

5.4.2 Rack and Pinion Drive System

This section applies to a MCWP elevated by a power operated rack and pinion drive system.

5.4.2.1

Means shall be provided to maintain the rack and the driving or any safety gear pinion constantly in mesh under all conditions of load. Such means shall not rely upon the platform guide rollers. The devices used shall restrict movement of the pinion on its axis such that at least two-thirds of the tooth is always in engagement with the rack.

5.4.2.2

In addition it shall not be possible for the pinion to move out of its correct engagement with the rack by more than one third of the tooth height, even in the event of failure of a counter roller or other mesh control feature or local bending or deflection of the mast.

5.4.2.3

The rack and pinion metric tooth module shall not be less than four (4) for drive systems where the counter roller or other mesh control feature reacts directly on the rack without the interposition of any other mast profiles. six (6) where the reaction of the counter roller or other mesh control feature is by means of another element of the mast which is then in immediate contact with the rack.

5.4.2.4

Any safety gear pinion shall be situated lower than the drive pinions.

5.4.2.5

The drive pinion shall be designed according to ANSI/AGMA 2001-C95, regarding tooth-strength, for a minimum of 10^8 load-cycles. The pinion shall be so dimensioned that, based on ANSI/AGMA 2001-C95, there shall exist a minimum safety factor of 1.5 based on the allowable stress number for

tooth-strength taking into account the actual stress induced in the teeth under the total suspended static load per pinion.

5.4.2.6

The rack shall be made from material having properties matching those of the pinion in terms of wear and shall be designed according to ANSI/AGMA 2001-C95, regarding tooth-strength, for a minimum of 10^4 load-cycles representing static strength.

The rack shall be so dimensioned that based on to ANSI/AGMA 2001-C95, there shall exist a minimum safety factor of 1.5 for tooth-strength for the actual stress induced in the teeth.

5.4.2.7

When more than one drive pinion is meshing with the rack, it shall only be permissible to share the design loads between the pinions, if a self-adjusting measure is provided to guarantee load sharing under all normal running conditions.

5.4.2.8

A pinion shall never be used as a guide roller.

5.4.2.9

Visual examination of all the pinions shall be possible without removal of the pinions or major disassembly of structural components of the MCWP.

5.4.3 Ratchet Drive Systems

This section applies to a MCWP elevated by a power operated ratchet drive system.

5.4.3.1 General requirements

5.4.3.1.1

The maximum rated speed when raising and lowering the platform shall be no more than 12 ft/min (0.06 m/s).

5.4.3.1.2

Means shall be provided to ensure the proper engagement of the drive system or any safety device on the rungs or other elements of the mast. Such means shall not rely on the platform guide rollers.

5.4.3.1.3

Visual examination of the drive mechanism shall be possible without major disassembly.

5.4.3.1.4

A drive mechanism shall never be used as a guide roller.

5.4.3.2 Design requirements**5.4.3.2.1**

The drive system shall always have at least one contact point fully engaged with the mast.

5.4.3.2.2

The drive system shall be designed in accordance with 5.1.

5.4.3.2.3

The ratchet drive mechanism shall be designed in accordance with generally accepted engineering principles using a minimum fatigue safety factor of 1.5 taking to account the actual stress induced under the total suspended static load. The fatigue load cycles shall be 10^6 for the dynamic component of the drive mechanism.

5.4.3.2.4

When more than one drive unit is used on the same mast, it shall only be permissible to share the design loads between the drive units if a self adjusting measure is provided to ensure load sharing under all normal running conditions.

5.4.3.3 Safety devices for ratchet drive systems**5.4.3.3.1**

The MCWP shall be provided with a safety device that meets the applicable requirements of section 5.5 and that will prevent the platform from free falling in the event of a failure of the drive system.

5.4.3.3.2

The safety device shall be situated lower than the drive system.

5.4.3.3.3

The components of the mast supporting the safety device shall have safety factor of 2.5 based on the ultimate strength of the material and the highest force that can occur at the rated load and maximum possible speed.

5.4.3.4 Lower travel limit switches**5.4.3.4.1**

Ratchet drive systems need not be provided with lower travel limit switches if the drive unit cannot induce uplift forces into the mast or base. The base may act as the buffer if the requirements of section 5.4.6.2 are met.

5.4.3.5 Upper travel limit switches**5.4.3.5.1**

Upper travel limit switches are not required where the ratchet drive system cannot disengage the guide rollers with the mast.

5.4.4 Screw Drive Systems

This section applies to a MCWP elevated by a power operated screw drive system.

5.4.4.1 General

The screw drive components shall be designed using a fatigue safety factor of 1.5 taking into account the actual stress induced under the total suspended static load. The fatigue load cycles shall be 10^4 for the rack component and 10^8 for the dynamic components of the drive mechanism.

5.4.4.2 Rack

The rack or similar support device shall be securely attached to the mast. Adjacent sections of the racks on the adjacent mast sections shall be accurately aligned to avoid faulty meshing or damage to the drive system.

5.4.4.3 Screw drive unit**5.4.4.3.1**

Means shall be provided to maintain the rack and any screw drive unit constantly in mesh under all conditions of load. The guide rollers used shall restrict movement of the screw system on its axis such that there is adequate engagement with the rack and screw drive unit to ensure it's safe operation.

5.4.4.3.2

It shall not be possible for the screw drive to move out of its correct engagement with the rack by more than one third of the contact surface, even in the event of failure of a counter roller or local bending or deflection of the mast.

5.4.4.3.3

When more than one drive screw is meshing with the rack, it shall only be permissible to share the design loads between the drive screws, if a self-adjusting measure is provided to guarantee load-sharing under all normal running conditions.

5.4.4.3.4

The safety device shall be situated lower than the drive system.

5.4.4.3.5

Visual examination of the drive screw shall be possible without removal of the drive screw or major disassembly of structural components of the MCWP.

5.4.4.4 Lower travel limit switches

Lower terminal stopping and lower final limit switches need not be provided if all of the following conditions are met:

- 1) The maximum speed of descent does not exceed 39 ft/min (0.2 m/s) under all circumstances including operation of the safety system (5.5.1.1) .
- 2) Buffers are provided which have no moving parts and are designed for repeated use without wear.
- 3) The buffer is designed according to 5.4.6 taking into account the possibility that the platform may be driven into the buffer.
- 4) The drive system is designed with a load-limiting device that limits the strain on the drive in the event the platform can be driven into the buffer and the drive system shall be designed taking into consideration the resulting forces.

5.4.4.5 Upper travel limit switches

Screw drive systems are not required to be provided with upper terminal stopping or upper final limit switches where;

- 1) the MCWP is designed so that the uppermost guide rollers or shoes cannot run off the top of the guides during normal operations,
- 2) the work platform cannot be driven off the top of the mast under any circumstances; and, the platform remains stable in the horizontal position according to 5.3.1.1 under all conditions including erection and maximum unbalanced platform loading.

5.4.5 Braking system**5.4.5.1 General requirements****5.4.5.1.1**

Every work platform shall be provided with a brake system which operates automatically:

- a) in the event of loss of the main power supply.
- b) in the event of loss of the supply to control circuits.

If two or more masts are used there shall be a braking ability for each mast.

Belts or chains for coupling the drive pinion to the component on which the brake operates are not permitted.

5.4.5.1.2

The braking system on its own shall be capable of stopping the platform, travelling at rated speed and with 1.25 times the rated load with a retardation between 0.2 and 1.0 g. In addition the braking system on its own shall be capable of stopping the machine when travelling at the triggering speed of the overspeed detector with the rated load.

5.4.5.1.3

In the case of only one brake, all the mechanical components of the brake which take part in the application of the braking action on the drum or disc or drive pinion shall be constructed and installed in such a way that if a failure in one of them occurs sufficient braking shall remain to bring the work platform with rated load to a stop.

5.4.5.1.4

The components on which the brake operates shall be positively coupled to a sprocket, drive pinion or similar device.

5.4.5.1.5

Any machine fitted with an emergency lowering or raising device according to 5.6 shall be capable of having the brake released manually and require a constant effort to keep the brake open.

5.4.5.1.6

The action of the brake shall be exerted by compression springs. The springs shall be adequately supported and shall not be stressed in excess of 80 % of the torsional elastic limit of the material.

5.4.5.1.7

Brake blocks and linings shall be of incombustible material (the use of asbestos is forbidden) and shall be so secured that normal wear does not weaken their fixings.

Brakes shall be provided with means of adjustment.

The braking system shall be protected against ingress of lubricants, water, dust or other contaminants to at least NEMA 1.

5.4.5.2 Special requirements for electromechanical brakes**5.4.5.2.1**

In normal operation, a continuous flow of current shall be required to hold off the brake.

The interruption of this current shall be effected by at least two independent electrical devices, whether or not integral with those which cause interruption of the power supply of the drive motor.

If, when the work platform is stationary, one of the contactors has not opened the main contacts, further movement shall be prevented at the latest at the next change in the direction of motion.

5.4.5.2.2

When the motor of the work platform is likely to function as a generator, it shall not be possible for the electric device operating the brake to be fed by the driving motor.

Braking shall become effective without delay after opening of the brake release circuit (the use of a diode or capacitor connected directly to the terminals of the brake coils shall not be considered as a means of delay).

5.4.5.3

Special requirements for hydro-mechanical brakes

5.4.5.3.1

In normal operation a continuous oil pressure shall be required to hold off the brake.

5.4.5.3.2 When the motion of the platform is initiated, the braking system shall not reach the hold off position before the normal operating torque for the drive is attained.

5.4.6 Buffers**5.4.6.1**

Where the deceleration of the work platform at the bottom limit of travel of the work platform could exceed 1.0 g, buffers shall be provided.

5.4.6.2

The total possible stroke of the buffer(s) shall be at least equal to the stopping distance corresponding to the work platform with rated load, being arrested by the buffers from its maximum possible speed at a deceleration of 1.0 g. The maximum possible speed to be considered shall be that which can occur in service or the tripping speed of the overspeed safety device or speed limiting system whichever is the greater.

5.4.6.3

If the buffers travel with the work platform they shall strike against a clearly recognizable pedestal.

5.5 Means to prevent the work platform from falling with overspeed**5.5.1 General****5.5.1.1**

All MCWP's shall be equipped with a device, or means which prevents the work platform from falling in the event of any failure (other than a structural failure of the mast/work platform) and which operates before a speed of 100 FPM (30 m/min) is exceeded. This device, or means, shall automatically arrest and sustain the work platform with 1.1 x the rated load.

These devices or means shall, when tripped cause a deceleration not less than 0.05 g and not more than 1.0 g.

This shall be achieved by one of the following systems:

- a) an Overspeed Safety Device or
- b) two or more independent and identical direct drive units fitted to each mast

5.5.1.2

Adjustable components which have a safety related function shall either require tools for

their adjustment or be capable of being sealed against unauthorized adjustment.

5.5.1.3

These devices or means shall be designed to ensure that environmental conditions cannot affect their safe operation.

5.5.2 Overspeed safety device

5.5.2.1 Design requirements

The overspeed safety device specified in 5.5.1.1a) shall:

- a) be independent of the drive machinery other than the rack or rungs
- b) be always fully operational in normal use, erecting, maintenance and dismantling.
- c) not be dependent on energizing or maintaining an electrical or other auxiliary circuit.
- d) accessible for inspection, maintenance and testing without major dismantling
- e) be designed using a safety factor of 2.5 based on the ultimate strength of the material and the highest force which can occur in the device with rated load and maximum possible speed (see 5.5.1.1).
- f) be able to be tested by a competent person remote from the work platform so that persons are not exposed to danger.
- g) not be used for guidance of the work platform.
- h) positively actuate on the masts or racks and be tripped by an overspeed detector (See 5.5.2.2).
- i) be designed so that all control circuits for normal operation are automatically interrupted by a safety switch before or at the time the overspeed safety device is applied.
- j) be designed so that the method of release of the safety device requires the intervention of a competent person in order to return the MCWP to normal operation.
- k) be designed such that the braking effect of the overspeed safety device increases progressively from the point of tripping of the overspeed governor to the point of bringing the platform to rest.

5.5.2.2 Overspeed Detector

5.5.2.2.1

The Overspeed Detector shall trip at a speed defined by the manufacturer, but in no case shall the work platform exceed the speed stated in 5.5.1.1.

5.5.2.2.2

Overspeed Detector shall operate mechanically and shall be driven by the overspeed safety device or by rope.

5.5.2.2.3

If ropes and pulleys are used for overspeed detector

- the wire rope diameter shall not be less than $\frac{1}{4}$ in. (6 mm);
- the ratio between the diameters of the rope pulley and the wire rope shall not be less than 20:1;
- the ratio between the minimum breaking force of the wire rope to the highest pull forces which could occur in the wire rope shall not be less than 8:1;
- the minimum generated force shall not be less than 67.5 lbf (300 N) and not less than twice the force necessary to engage the Overspeed Safety Device.

5.5.3 Multiple drive units

Where multiple drive units are used to meet the requirements of section 5.5.1.1 b), the following shall apply:

- a) The MCWP shall have at least two or more independent and identical capacity direct drive units fitted to each mast. Each drive unit shall have its own brake, and each brake unit shall be completely independent and be positively but separately connected to the mast.
- b) In the event of the failure of a drive unit or its braking system, the remaining braking system shall be capable of stopping and sustaining the work platform when carrying $1.1 \times$ rated load, from the maximum possible speed even under emergency lowering conditions (see 5.6).

In addition, each brake shall have a minimum capacity of 2 times the design load of each drive unit.

- c) Each drive unit shall always be fully operational in normal use, erection, maintenance and dismantling.
- d) The brake mechanism shall be able to be tested to verify the requirements of sub clause b).
- e) The brake system shall be accessible for inspection, maintenance and functional testing of the system without major dismantling.
- f) Each drive unit, including the rack where applicable, shall be designed using a safety factor of 2.5 based on the ultimate strength of the material and the highest force that can occur in the drive at the rated load and maximum possible speed.
The load on each drive unit shall be determined considering the failure of at least one drive unit.
- g) The drive system shall detect a malfunction in any drive unit that impedes its proper function, and when the malfunction is detected, the brakes shall be automatically applied and the normal operation of the drive system shall be prevented.
Electrically powered drive systems shall at least indicate a loss of mechanical integrity, which results in a differential in the current demand between each drive unit exceeding 25% of the full-load current.
Hydraulically powered drive systems shall at least indicate a loss of mechanical integrity, which results in a differential in the torque demand between each drive unit exceeding 25% of the full-load torque.
- h) The drive system shall have a speed limiting system that automatically prevents the work platform from exceeding a descent speed of 79 ft/min (24 m/min).
The speed limiting system shall be capable of carrying the work platform and its rated load in the most disadvantageous configuration, and shall have a safety factor of at least 2.5 based on the ultimate strength of the material and the highest force which can occur in the event of the failure of a brake or mechanical failure occurring in a drive unit.

5.6 Means for emergency lowering and raising the work platform

5.6.1

The MCWP shall be equipped with the means to lower the platform in emergencies or other circumstances. Such circumstances shall include power system failures but may exclude those mechanical failures which would prevent the safe movement of the work platform.

The means for emergency lowering is intended to permit controlled movement of the platform to a level which will allow personnel to safely exit the platform.

5.6.2 The means shall:

- a) be operated from a safe, but easily accessible location on the work platform which also permits the best possible view of the travel area.
- b) have controls which are adequately shrouded or otherwise arranged to prevent, as far as possible, accidental operation from any cause.
- c) only be operable by a hold-to-run control which permits lowering of the work platform only as long as the control is manually held in a set position by a manual force of no more than 90 lbf (400N).
- d) require the temporary release of the braking system (see 5.4.3).
- e) require the immediate automatic re-application of the braking system upon release of the emergency lowering controls.
- f) be capable of lowering the work platform with 1.1 x rated load.
- g) not allow any part of the work platform to exceed $\pm 5^\circ$ from the horizontal, according to 5.3.1.1, during emergency lowering.

5.6.3

The emergency lowering means shall not prevent the operation of the devices according to 5.5.1.1 a).

5.6.4

Means for emergency raising of the work platform may be provided in addition to the means for emergency lowering. When provided, the emergency raising means shall comply with 5.6.1 and 5.6.2 as well as 5.6.3

with the word raising substituted for lowering in all cases.

5.7 Overload/moment device

5.7.1

The MCWP shall be provided with an overload and moment detecting and indicating device. For exception see 5.7.16.

5.7.2

This device shall detect the total load due to persons, equipment and materials on the work platform. It shall also detect those moments due to these loads, that are likely to lead to overturning or failure of the MCWP. This device shall at least detect:

- bending and torque moments on cantilevered main platforms
- bending and torque moments on the central part of simply supported main platforms
- bending moment on the mast

5.7.3

Overload moment detection shall be capable of being carried out at least while the work platform is stationary.

5.7.4

The overload/moment detector shall be consistent with the rated loads and their location shown or described on the rated load chart(s) for the MCWP.

5.7.5

The load and moment detection and indication shall function.

- a) automatically for the different possible platform configurations, or
- b) if automatic detection and indication are not possible for different configurations, then a work platform configuration selector shall be provided which allows a clear classification of the chosen setting in comparison with actual work platform configuration. This can be done by either

- 1) a clear sign of the respective platform configuration
- or

2) a code at each setting. In this case a clear reference shall be given to the explanation of the code on a separate code or configuration sign.

5.7.6

The number of possible selections permitting use of the work platform shall not exceed the number of configurations for the work platform.

5.7.7

The selector shall be so situated or protected so as to be inaccessible to unauthorized persons.

5.7.8

The overload/moment detector shall be triggered before reaching a load/moment of 1.1 x rated load/moment and once triggered shall continuously isolate the controls concerned until the overload/moment has been removed.

5.7.9

The design and installation of overload/moment detectors and indicators shall take into account the need to test the MCWP with overloads without dismantling and without affecting the performance of the detector or indicator.

5.7.10

The overload/moment indicator shall continuously, visually and audibly, warn the operator and other persons in the vicinity of the work platform when the overload/moment detector is activated.

5.7.11

No provision shall be made for the user to cancel the warning.

5.7.12

Visual warnings shall be positioned to be in full view of persons on the work platform.

5.7.13

The overload/moment detector and indicator shall be arranged so that their operation (but not necessarily their accuracy) can be checked without applying loads to the work platform.

5.7.14

The overload/moment detector and indicator shall comply with 105.10.

5.7.15

The electrical and electronic requirements for overload detection devices are given in Annex C.

5.7.16

Devices according to 5.7.1 to 5.7.15 are not required if the following demands are met:

All design calculations are based on the loads m_p , m_e and T , that are related to the rated load 'm' in 5.1.2.2.1 increased by a further factor f as a function of 'm' according to figure 8.

Brakes and safety devices/means are calculated with the same loads as mentioned in the previous paragraph.

For stability calculations the increased loads are considered in case they give overturning moments.

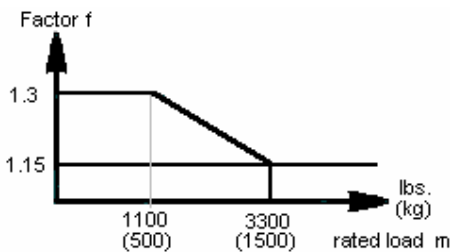

Figure 8
Factor f as a function of rated load

5.8 Electrical systems

5.8.1 General

5.8.1.1

Electrical and electronic installations and their appliances shall be in accordance with ANSI/NFPA 70, which applies in full.

5.8.1.2 A main switch according to ANSI/NFPA 70-1996 shall be mounted on the chassis or base at an easily accessible position.

5.8.1.3

Drive systems shall have a power supply disconnecting device within 6 ft 6 in (2.0m) from the drive.

5.8.1.4

Safety and control circuits shall be in accordance with ANSI/NFPA 70-1996. The safety and control circuits shall be electrically separated from all other circuits.

5.8.1.5

Transformers shall be used for supplying control circuits. Such transformer shall have separate winding and one side of the control circuit shall be connected to the protective bonding circuit (see ANSI/NFPA 70-1996).

5.8.1.6

All safety contacts shall be of positive opening operation type.

5.8.1.7

In the event of a failure of one phase of the supply to the directional control device, the machine shall stop.

5.8.1.8

Precautions shall be taken to ensure the free and safe movement of any trailing cable throughout the full range of travel of the work platform. Where the mast is inclined or where multilevel work platforms to option B (annex B) are used, additional precautions are necessary, for example by making the cable follow the incline of the mast by the use of guides or the use of automatic cable reeling drums.

5.8.2 Safety switches

The operation of a safety switch shall be by positive separation of the contacts, even if the contacts have welded together. Safety switches shall comply with 5.8.1.6 and the conditions set out in table 7 below

TABLE 7
1.4.1.1.1.1.1.1 Conditions for use of electric switches

Clause	Devices checked	Switch
5.3.4.6	Separation distance switch	sc
5.5.2.1 i	Operation of overspeed safety devices	sc
5.12.1	Terminal stopping switch	ssr
5.12.2	Final limit switch	sc
Abbreviations: ssr = safety switch, self resetting sc = safety switch in a safety circuit		

5.8.3 Control systems

The control system shall comply with what stated in table 7. This includes any control system using electrical or hydraulic power.

The control system shall be designed so that a single malfunction in the control system will not result in continuous uninterrupted unintended movement of the platform.

In redundancy-type circuits and diversity-type circuits measures shall be taken to limit as far as possible the risk of defects occurring simultaneously in more than one circuit arising from a single cause.

5.9 Drive systems powered by internal combustion engines

5.9.1

Guards shall be provided to protect persons at control positions, or standing adjacent to the MCWP at ground level, or at other points of access, against thermal or mechanical hazards.

5.9.2

The exhaust from internal combustion engines shall be directed away from control positions.

5.9.3

The filling points of gas and fluid reservoirs (other than for fire resistant fluids) shall be positioned to avoid any fire from spillage onto very hot parts. (eg. engine exhaust)

5.9.4

An appropriate fire extinguisher shall be provided with the MCWP in a suitable location where flammable fuels are used.

5.9.5

Batteries and containers shall be constrained to prevent displacement which could create a hazard.

5.9.6

Suitable ventilation holes shall be provided in the battery container, compartment, or cover to prevent the accumulation of gases.

5.10 Hydraulic systems

5.10.1 General

5.10.1.1

The hydraulic system shall be designed so that where the elevation of the platform is accomplished by hydraulic means, the system shall prevent uncontrolled descent in the event of a hydraulic system failure.

5.10.1.2

It shall be the responsibility of the manufacturer to determine, by calculations and test, the working pressures which can occur in any part of the circuit.

5.10.1.3

Each hydraulic circuit shall be provided with a sufficient connection for a pressure gauge to allow checking for correct pressure.

5.10.1.4

The design of the hydraulic system shall enable entrapped air to be vented.

5.10.1.5

Any hydraulic tank open to atmosphere shall be equipped with an air-breathing filter.

5.10.1.6

Each fluid reservoir tank shall be equipped with easily accessible devices indicating both the permissible maximum fluid level and the necessary minimum level.

5.10.1.7

The hydraulic system shall be fitted with a pressure-relief valve in order to provide protection against excess pressure. It shall be adjustable, sealed and designed to resist tampering. The valve shall be adjusted for a pressure which is no more than 20 % above the pressure in operation with the rated load. If different maximum pressures are used in the hydraulic system, then a corresponding number of pressure-relief valves shall be provided.

5.10.1.8

Pipes and their connections, which may be subjected to the maximum pressure permitted by any pressure-limiting device, shall be designed to withstand at least twice that pressure without permanent deformation. If in

normal operation component may be subjected to higher pressure than permitted by the pressure-limiting device, they shall be designed to withstand at least twice that higher pressure without permanent deformation.

5.10.1.9

The bursting pressure of hoses, including fittings, which may be subjected to the maximum pressure permitted by the pressure-relief valve shall be not less than four times that pressure.

5.10.1.10

All other parts of the hydraulic system shall be designed to withstand at least two times the maximum pressure to which they will be subjected without permanent deformation

5.10.1.11

Pilot-operated control valves shall be so designed and installed that they fail to a "safe" condition in the event of power failure.

5.10.2 Hydraulic cylinders

5.10.2.1

Hydraulic cylinders shall be designed and installed in accordance with the applicable standard for fluid power systems and components (SAE J514, J516 and J517 or equivalent)

5.10.2.2

The design of threaded joints subjected to varying tensile loads shall take into account the effects of fatigue and prevent inadvertent separation (unscrewing). The visible threaded joints shall be marked with a line of paint for easy checking of unscrewing.

5.10.2.3

Load holding cylinders shall be fitted with a device to prevent unintended movement caused by failure of an external pipe until they are opened by an external force.

The device shall be either:

- a) integral with the cylinder, or
- b) directly and rigidly flange-mounted, or
- c) placed close to the cylinder and connected to it by means of rigid pipes (as short as possible), having welded or flanged connections and being calculated in the same way as the cylinder.

5.11 Special requirements for safety devices that depend on auxiliary circuits

5.11.1

The device shall be compatible with the designed use of the MCWP.

5.11.2

Systems shall enable periodic functional checks to be carried out to verify that all functions are operating correctly.

5.11.3

If interruption of the power occurs, all data and calibration of the indicators shall be retained.

5.11.4

Limiting and indicating device systems shall fail to a "safe" condition, in which any fault results in a shutdown of the control circuits for normal operation.

5.12 Travel limit switches

5.12.1

Terminal stopping switches shall be provided and positioned so that they automatically stop the work platform from rated speed at the highest and lowest levels. At the lowest level, initiation of stopping should occur before contact with the buffer and before contact with the final limit switch. At the highest level, initiation of stopping shall occur before contact with the final limit switch.

5.12.1.1

Terminal stopping devices required by rule 5.12.1 shall be permitted to use mechanically operated, or solid state type devices for determining the platform position.

5.12.2

An upper final limit shall be provided. It shall be positioned such that the work platform will come to a complete stop before reaching the top of the mast. After triggering the upper final limit switch, downward movement of the work platform may be permitted but no further upward movements shall be possible until corrective action has been taken by a competent person.

A lower final limit switch shall be provided. It shall interrupt the electric supply such that the

work platform is not powered into the buffers. After triggering the lower final limit switch all movements of the work platform shall be prevented until corrective action has been taken by a competent person.

5.12.2.1

Final terminal stopping devices required by rule 5.12.2 shall:

- a) be mechanically operated;
- b) have operating cams made of metal;
- c) have switch contacts which are directly opened mechanically. Arrangements which depend on a spring or gravity, or a combination thereof, to open the contacts shall not be used.

5.12.3

Separately mounted actuating and control devices shall be used for the terminal stopping (travel limit) switches and the final limit switches.

It is permitted to have one final limit switch to serve both the upper and lower limit switch functions.

5.13 Controls

5.13.1

On self-propelled MCWP it shall not be possible to operate the vertical movement of the platform and the horizontal movement for transfer simultaneously.

5.13.2

The control device for normal vertical movement shall be situated on the work platform only. The control device for horizontal movement of the MCWP-chassis shall not be situated on the platform.

5.13.3

If movement can be controlled from different control positions, the controls shall be interlocked in such a way that control is only possible from one pre-selected control position.

5.13.4

Platforms shall be provided with hand operated controls such that all movements of the platforms can only take place while the control is being actuated. When released, the controls shall automatically return to the neutral position.

All controls shall be arranged to prevent inadvertent operation.

5.13.5

While moving the platform vertically, the control station shall be positioned to provide the operator with the best possible view of the travel area and to ensure safe movement of the platform. A warning sign shall be mounted on any portable control station stating that vertical operation of the work platform from places other than the work platform itself is forbidden. For multilevel platforms under Annex B Option A no personnel are allowed on the secondary platform while moving the platform vertically.

5.13.6

Emergency stop controls shall be arranged on the platform. When activated, this switch shall cause the power to be removed from the platform drive system, motor and brake.

5.13.6.1 Emergency stop switches shall:

- a) be of the manually opened and closed type;
- b) have red operating handles or buttons;
- c) be conspicuously and permanently marked "stop" and shall indicate the stop and runs positions;
- d) be positively opened mechanically and their opening shall not be solely dependent on springs.

5.13.7

On starting, or restoration of the power after failure of the power supply, no further movement shall occur without the intervention of the operator.

SECTION 6

VERIFICATION OF SAFETY REQUIREMENTS AND/OR MEASURES FOR EACH NEW MODEL OF MCWP

Examinations and tests for each new model of MCWP shall be performed by the manufacturer.

6.1 Design check

The design check shall verify that the MCWP is designed in accordance with this standard. It will include the verification of the following documents:

- a) drawings containing the main dimensions of the MCWP.
- b) description of the MCWP with necessary information about its capabilities
- c) information about the materials used.
- d) diagrams of the electrical, hydraulic and pneumatic circuits.
- e) operating instructions.

The above documents shall give all necessary information to enable:

- the stability calculations to be checked (see 5.1.5).
- the structural calculations to be checked (see 5.1.4).

6.2 Practical tests

6.2.1 General

Practical tests shall be made to verify that the MCWP is stable, the MCWP is structurally sound, and all functions work correctly and safely.

These tests shall be made:

- a) In the case of a freestanding MCWP, with the mast erected to its maximum freestanding height.
- b) In the case of a tied-in MCWP, with at least two ties in position at their maximum permitted spacing with maximum permitted top overhang.

MCWP's which are capable of operating in both freestanding and tied-in conditions shall be tested in both configurations.

6.2.2 Stability tests

6.2.2.1 General

The MCWP shall be set up on the maximum allowable inclination of the chassis defined by the manufacturer plus 0.5° with outriggers (if fitted) used as specified by the manufacturer. Test loads shall be applied to represent all the most unfavorable load and force combinations specified in 5.1.5.

The test may be carried out on level ground if the test loads are recalculated to include the

effects of the maximum allowable inclination of the chassis defined by the manufacturer plus 0.5°.

The test loads may be applied at any suitable strong point, if necessary, to avoid overstressing any part of the MCWP.

The test shall be repeated in all the most unfavorable extended and/or retracted positions.

The untied MCWP is stable if it can come to a stationary condition without turning over while supporting the test load and force combination(s).

6.2.2.2 Braking test of the chassis

All MCWP's fitted with powered wheeled chassis shall be subjected to a brake test with the unloaded platform in the worst transfer condition. The brake shall be able to stop and hold the MCWP in the worst transfer condition. Application of the brake shall not induce instability.

6.2.2.3 Overload test

The test load shall be 125% of the rated load. All movements with the test loads shall be carried out at accelerations and decelerations appropriate with safe control of the load.

When, due to the various combinations of load(s) or extensions of a MCWP tests with different test loads are necessary, all movements shall be carried out with all test loads except where the most unfavorable conditions can be sufficiently simulated by one performance test.

During the overload test, the test load shall be put into each position which creates maximum stress in any load carrying part of the MCWP.

During the overload test, the brakes shall be capable of stopping and sustaining the test load(s). After removing the test load(s), the MCWP shall show no permanent deformation.

The overload/moment device, if provided, shall be checked for compliance with 5.7.3 to 5.7.14.

6.2.2.4 Functional tests

6.2.2.4.1 General

Functional tests shall demonstrate that:

- a) the MCWP can operate smoothly for all motions while carrying the rated load at the rated speeds.
- b) all safety devices work correctly.
- c) maximum permitted speeds are not exceeded.

6.2.2.4.2

Test of the systems to prevent the work platform from falling with overspeed according to 5.5.1.1.

Functional tests of the overspeed safety device shall be carried out with the platform carrying 1.1 times the rated load. The work platform shall be allowed to overspeed to the governor tripping speed in order to determine that:

- a) the overspeed safety device operates as specified by the designer, and
- b) the overspeed safety device is capable of arresting the motion of the work platform without the assistance of motor brakes and is within the designers/manufacturers quoted stopping distance.

6.2.2.4.3

Test of the systems to prevent the work platform from falling with overspeed according to 5.5.1.1

Functional tests of the independent drive units shall be carried out with the platform carrying 1.1 times the rated load. It shall be determined that:

- a) the work platform can be stopped and sustained from rated speed by each of the drive units in turn by intentional release of the motor brake of each one of the drive units in turn during the test.
- b) the platform can be stopped and sustained from rated speed by intentional activation of the safety system.
- c) in each case, the stopping distance is within the designer's quoted specification.

6.2.2.4.4

Test of the means for emergency lowering (and raising if applicable) of the work platform

a) For work platforms equipped with Overspeed Safety Device according to 5.5.1.1. a) check that the controls comply with 5.6.1 and 5.6.2 and that the work platform speed with 1.1 times the rated load can be controlled according to the user instruction. While lowering, permit the speed to increase further to the point where the overspeed safety device-operates, according to 5.6.3.

b) For work platforms equipped with means according to 5.5.1.1. b), check that the controls comply with 5.6.1 and 5.6.2 and that the lowering (and raising, if applicable) speed does not exceed 60 FPM (18 m/min) with 1.1 times the rated load on the work platform.

SECTION 7 INFORMATION FOR USE

7.1 Operating manual

7.1.1 Comprehensive information

Manufacturers or suppliers of MCWP shall supply sufficient comprehensive information for the safe use of the MCWP.

7.1.2 Content of the Operating manual

Weather resistant storage: Manufacturers shall provide a weather resistant storage location on the Mast Climbing Work Platform for the appropriate manual(s).

The manufacturer and/or importer/supplier shall make available to the user an instruction handbook containing at the least, information about the following topics:

7.1.2.1 General information

Manufacturers or suppliers name and address
 Country of manufacture
 Model designation
 Serial or fabrication number
 Year of manufacture
 Vertical travel speed FPM (m/s)
 Horizontal transfer speed FPM (m/s)
 Outdoor/indoor installation
 Maximum allowable freestanding height in and out of service ft (m)
 Maximum allowable wind speed during erection and dismantling MPH (m/s)

Maximum allowable wind speed in and out of service MPH (m/s)

Hydraulic supply information if an external hydraulic power supply is used.

Pneumatic supply information if an external pneumatic power supply is used

Electrical supply information if an external electric power supply is used

Fuel supply information if an external fuel supply is used

Warning sign required regarding moveable control stations

7.1.2.2 Capacity information

The following information shall be made available, both for MCWP with non-varying work platform configuration and for MCWP with varying work platform configurations. In the case of variable configuration designs, the rated loads for particular main platform and platform extension configurations and any limitation as to load distribution shall be displayed each time the MCWP is installed (see 7.2.3).

- a) Maximum platform dimensions ft (m) (length x width including platform extensions)
- b) Rated load lbs (kg)
- c) Maximum lifting height, untied mast ft (m)
- d) Maximum lifting height, bed mast ft (m)
- e) Tie distance ft (m)
- f) Top overhang in operation ft (m)
- g) Maximum permitted force applied to tools (manually or mechanically assisted) which is to be reacted by the work platform lbf (N)
- h) Maximum rated load on platform extensions lbs (kg)
- i) Any load permitted on the work platform during transfer condition lbs (kg)

Sufficient information shall be given in the instruction handbook provided by the manufacturer such that the owner can derive the particular details for each configuration. These particular details shall then be augmented by the name of the erection site and a reference to the relevant chapter in the instruction handbook, such that the user can display this load diagram on the MCWP.

7.1.2.3 Dimensions and weights

Height from the ground to the work platform in its lowest position for access ft (m)

Platform section: length x width x height ft (m)

Platform section: weight lbs (kg)

Mast section: length x width x height ft (m)

Mast section: weight lbs (kg)

Drive unit: length x width x height ft (m)

Drive unit: weight lbs (kg)

Chassis: length x width x height ft (m)

Chassis: weight lbs (kg)

Outrigger spread and configuration: length x width ft (m)

Base unit (specified transport configuration): weight and dimensions length x width x height ft (m)

MCWP installed by crane: weight lbs (kg)

MCWP installed by crane: max height of mast ft (m)

Minimum area required for installation: length x width ft (m)

7.1.2.4 Electrical data

Power - lifting machinery (kW)

Power - transfer machinery (kW)

Supply voltage/frequency (V/Hz)

Control voltage/frequency (V/Hz)

Maximum starting current (A)

Maximum power consumption (kVA)

Minimum power supply (kVA)

Main power supply fuses and type (A)

Outlets for portable tools - voltage and current (V, A)

7.1.2.5 Safety equipment

Type of safety equipment

- a) overspeed safety device terminal stopping switches
- b) final limit switches
- c) Additional safety equipment for erection and dismantling
- d) Emergency lowering equipment.

7.1.2.6 Additional technical information

This shall include the following:

- a) Outrigger arrangements
- b) Ground bearing pressure and the hazards associated with changing ground conditions.

- c) Tie arrangement and forces imposed on the supporting structure, for given wind zones.
- d) Freestanding arrangements for given wind loads.
- e) Need for protection regarding hazardous areas around the MCWP.
- f) Provision of adequate lighting for safe operation.
- g) Precautions about platform extension between the building and the mast.
- h) Information regarding any lifting points.
- i) Consideration of the possible requirements for lightning protection.
- j) Consideration of the effects of any item which significantly increases the wind area (see 105.1.2.3.3).
- k) Consideration of any effects which significantly increases the wind speed i.e. adjacent tall buildings etc.
- l) Instructions indicating that any non-standard configurations required these shall be agreed upon between the manufacturer, the owner and the user.
- m) Transport procedure to and from site including the need for meeting the traffic regulations.
- n) Transfer of the MCWP around the site including maximum gradient.
- o) Instructions with regard to the use of slightly raised outriggers during transfer conditions in order to avoid instability from, for instance, failure of one tire.

7.1.2.7 Operation Instructions

These shall include the following:

- a) Operating procedures, including information on safe distances such as the clearance to power cables and other overhead structures and between the platform and the building.
- b) Emergency procedures, including the operation of safety devices, resetting by a qualified person and action to be taken in case of power loss, including the safe use of the means for emergency lowering. This must include clear instructions regarding the safe lowering distance increments and any rest periods needed in order to avoid the overheating of brake linings.
- c) Instructions indicating that transfer controls cannot be operated with any other movement unless the MCWP is in transfer condition.

7.1.2.8 Operating personnel requirements

The instruction handbook shall state to the user the minimum training requirements of personnel.

7.1.2.9 Operating procedure requirements

These shall include the following:

- a) Each day before the MCWP is taken into use, the user shall check the operating devices, i.e. brakes, emergency stops, the condition of all trailing cables, travel limit switches, guardrails, structural connecting mast ties, cables, guide rollers, and information plates, etc.
- b) Keep the work platform clean from waste, debris, snow, etc.
- c) Before any work is commenced, the operator shall visually check the outriggers and any timber or other packing on the ground shall be visually checked to ensure that it is in good order.
- d) Ensure that tools and other objects do not project outside the perimeter of the MCWP.
- e) During the work the operator shall carefully follow the operating instructions.
- f) At the end of the work period the platform shall be brought into the "out-of-service" position and it shall be isolated to prevent unauthorized operation.
- g) In the event of a fault with the MCWP, which can jeopardize safety, the operator shall immediately immobilize the MCWP and notify a competent person: In case of emergency the operator must follow the relevant instruction in the users manual.

7.1.2.10 Maintenance instructions

These shall include the following:

- a) Schedule of regular maintenance together with required adjustments and tolerances and the required intervals
- b) Information on precautions to be taken against hazards during maintenance
- c) Regular replacement of specific parts including discard criteria
- d) Information on the replacement of safety critical parts by identical components
- e) Information into how to seal adjustable components which have safety related functions
- f) Troubleshooting information

- g) Electrical/Hydraulic/Pneumatic schematic diagrams
- h) Parts lists/diagrams
- i) A list of the special maintenance work to be carried out only by trained personnel.
- j) The manufacturer shall stress that regular maintenance shall include visual inspection and necessary functional test and maintenance measures. Special attention shall be given to the inspection of load bearing parts with attachments, driving and stopping devices, operating and safety devices, racks and pinions, etc.

7.1.2.11 Periodic examinations and test on MCWP

The instruction handbook shall state that the frequency and extent of periodic examinations and tests depends on national and local regulations, manufacturers requirements, operating conditions and the frequency of use. It is normally not necessary to dismantle parts at periodic examinations, unless there are any doubts in relation to reliability and safety. The removal of covers, the exposure of observation apertures, and bringing the MCWP to the transport position are not considered to be dismantling.

The instruction handbook shall state the maximum time between periodic examinations and tests. Such examinations and tests shall at least consist of the following:

- a) a visual examination of the structure with special attention to corrosion and other damage of load bearing parts and welds
- b) an examination of the mechanical, hydraulic, pneumatic and electrical systems with special attention to safety devices

7.1.2.12 Instructions for erection and dismantling

These shall include the following:

- a) Detailed explanation of erection and dismantling procedure with special attention to mast assembly, mast tie system, platform and extension assembly.
- b) A description of special hazards which can arise during erection and dismantling, with a description of any additional safety equipment and how this may be used to reduce these hazards. The use of personal

protective equipment shall be mentioned in this section.

- c) Precautions regarding site preparation with special regard to the bearing capacity of the foundation, gantry, asphalt, etc.
- d) Precautions regarding instability during operation or transfer of the equipment.
- e) Procedures required when platform travel must be limited due to obstructions in the travelpath so that the platform does not reach the normal travel limit switches, and requirements for additional travel limit devices to protect persons and material on the platform or the platform itself from hazardous situations.
- f) Procedures to be observed when preparing the MCWP for transport.
- g) Loading procedures for transport or transfer.
- h) The clear gap between the ends of the adjacent MCWP shall be not less than 14 in (0.35m).

Precautions shall be taken to ensure the free and safe movement of any trailing cable throughout the full range of travel of the work platform. Where the mast is inclined or where multilevel work platforms to option B (annex B) are used, additional precautions are necessary, for example by making the cable follow the incline of the mast by the use of guides or the use of automatic cable reeling drums.

Where the platform is erected towards a wall the instructions shall furthermore contain information regarding the required height (h) of guard rails on the work platform depending on the distance (d) between the platform and the wall according to figure 9, table 8, and Section 105.3.2.

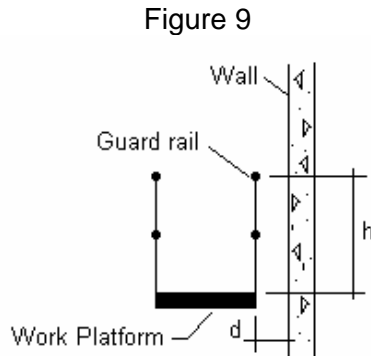

d-in [m]	≤ 14 [0.35]	>14 [0.35]	14 [0.35] $\leq d$ ≤ 18 [0.45]
h-in [m]	0	42 +/-3 [1.06] 1)	0 2)
1) with intermediate rail and toeboard according to 105.3.2.2. 2) for plastering and lathing operations			

Table 8: Height of guard rails

7.1.2.13

Examinations and tests after major alterations or major repairs to a MCWP already in use

Examination and test after major alterations or major repairs to MCWP's already in use shall consist of the following:

- design check (see 6.1.1)
 - practical tests (see 6.1.2)
- to an extent corresponding to the type of alteration or repair.

For the purpose of this Standard "major alterations" are modifications of the whole or part of a MCWP, which affect stability, strength or performance.

7.1.2.14 Check List

A list shall be provided in the instruction handbook which contains all safety relevant parts of the MCWP to be checked after each erection. The result of the checks after each erection and the name and address of

person(s) making it shall be recorded in a signed report.

7.2 Marking

7.2.1 General

The manufacturer shall provide the following information on one or more durable signs or plates mounted in a prominent place on the MCWP. Hazard Warnings, cautions, or instructions for safe operation conforming to applicable American National Standards Institute Standards Z535.1, Z535.2, Z535.3, and Z535.4.

7.2.2 Information, non varying

- a) Manufacturer's or suppliers name and address
- b) Country of manufacture
- c) Model designation
- d) Serial or fabrication number
- e) Year of manufacture
- f) Rated work load, including personnel and material.
- g) Vertical travel speed FPM(m/s)
- h) Transfer, travel speed FPM(m/s)
- i) Out /indoor installation
- j) Maximum allowable freestanding height ft.(m) in and out of service
- k) Limiting windspeed during erection / dismantling
- l) Maximum allowable windspeed in service/out of service MPH(m/s)
- m) Hydraulic supply information if an external hydraulic power supply is used
- n) Pneumatic supply information if an external pneumatic power supply is used
- o) Electrical supply information if an external electric power supply is used
- p) Fuel supply information if an external fuel power supply is used
- q) All guardrails to be in place at all times except for loading and unloading at the access level.
- r) Alternative configuration statement. If a MCWP has alternative configurations, then the manufacturer shall clearly describe these alternatives, including the rated capacity in each configuration. If the rated work load of a MCWP is the same in all configurations, these additional descriptions are not necessary.

- s) A statement of whether or not the platform and guardrail system are electrically insulated. If equipped with an insulated platform, the level of protection and applicable test standard shall be stated.
- t) A statement of compliance with this Standard.
- u) Warnings against replacing, without Manufacturer's consent, components critical to machine stability.

7.2.3 Information, varying

7.2.3.1 Capacity

A load diagram showing the rated loads for particular main platform and platform extension configurations and any limitation as to load distribution shall be displayed on the platform. This shall be derived from the information presented by the manufacturer according to 7.1.2.2.

The load diagram shall take the form of a durable sign or plate. It shall be the responsibility of the user to make sure the load diagram is in place.

The manufacturer shall provide a means of mounting the load diagram.

7.2.3.2

Additional technical Information
-Outrigger arrangements and required ground bearing pressure

7.3 Responsibilities of dealers

7.3.1 Basic principles

Sound principles of safety, training, inspection, erection, maintenance, applications, and operation consistent with all data available regarding the parameters of intended use and expected environment shall be applied in the training of operators, in maintenance, application, erection and operation of the MCWP with due consideration of the knowledge that the unit will be carrying personnel.

7.3.2 Manuals

- a) Dealers shall keep and maintain copy(ies) of the operating and maintenance

manual(s) required in Section 7.1 of this Standard.

- b) Copy(ies) of operating manual(s) shall be provided upon each rental or lease delivery.
- c) Copy(ies) of operating and maintenance manual(s) shall be provided upon each sale delivery.
- d) The operating manual(s) shall be stored in the location required by Section 7.1.2 of this Standard.
- e) These manual(s) are considered an integral part of the MCWP and are vital to communicate necessary safety information to users and operators.

7.3.3 Pre delivery preparation

MCWP's shall be inspected, serviced, and adjusted to Manufacturer's requirements prior to each delivery by sale, lease, or rental.

7.3.4 Maintenance safety precautions

Before adjustments and repairs are started on a MCWP, the following precautions shall be taken as applicable:

- a) All controls in the "Off" position and all operating features secured from inadvertent motion by brakes, blocks, or other means.
- b) Platform lowered to the full down position, If possible, or otherwise secured by blocking or cribbing to prevent dropping.
- c) Hydraulic oil/pneumatic pressure relieved from all hydraulic/pneumatic circuits before loosening or removing hydraulic/pneumatic components.
- d) Safety props or latches installed where applicable as described by the manufacturer.
- e) All electrical circuits shall be de-energized by a locking device or by lock out/tag out system to protect against electrical shock during maintenance.
- f) Limit access to maintenance work area by unauthorized persons.

7.3.5 Replacement parts

When parts or components are replaced, they shall be identical or superior to original MCWP parts or components.

7.3.6 Training

Whenever a dealer directs or authorizes an individual to operate a MCWP, he shall ensure that the individual has been trained under the direction of a qualified person in accordance

with the manufacturer's operating and maintenance manual and requirements listed in Section 7.6 of this Standard before operating the MCWP.

7.3.6.1 Training on delivery

The dealer shall offer appropriate training to facilitate owners, users and operators to comply with requirements set forth in this Standard regarding the inspection, maintenance, use, application and operation of the MCWP.

7.3.6.2 Familiarization on delivery

Upon delivery by sale, lease, rental or any form of use, the dealer shall have the responsibility with the person designated by the receiving entity for accepting the MCWP to:

- a) Identify the weather resistant compartment (for manual storage);
- b) Confirm the manuals, as specified by the manufacturer, are on the MCWP;
- c) Review control functions;
- d) Review safety devices specific to the model MCWP being delivered.

7.3.7 Operation

When a dealer operates a MCWP in sales demonstrations or otherwise for his beneficial use, he and his operating personnel shall assume the Responsibilities of Users as specified in Section 7.5 and Responsibilities of Operators as specified in Section 7.6 of this Standard.

7.3.8 Assistance to owners & users

If a dealer is unable to answer an owner's or user's question relating to rated load, intended use, maintenance, repair, inspection, or operation of the MCWP, the dealer shall obtain the proper information from the manufacturer, or equivalent entity should the manufacturer no longer be in business, and provide that information to owner or user.

7.3.9 Record retention

Dealer(s) shall retain the following records for at least three years:

- a) Name and address of the purchaser or lessee of each MCWP by serial number and the date of delivery.
- b) Records of the person(s) trained upon each delivery of a MCWP.

- c) Records of the pre delivery inspection performed prior to each delivery, including the name(s) of the individual(s) responsible for such work.

7.3.10 Proof of training

The dealer should provide trainees who successfully complete training a means to evidence they are trained. The dealer shall provide such proof if it is requested by the trainee. The document evidencing training shall include the following information:

- a) Name of trainee;
- b) Name of entity providing training or retraining;
- c) Name of trainer(s);
- d) Clear identification that training covered MCWP's;
- e) Date of training.

7.3.11 Record dissemination

Upon request, the dealer shall provide the following information:

- a) To the owner of the MCWP, a copy of frequent or annual inspections performed;
- b) To the owner of the MCWP, a copy of repairs accomplished;
- c) To user, proof of training for an operator, including name of trainer and date of training;
- d) To a user, the name of the person(s) receiving familiarization upon delivery of the MCWP.

7.3.12 Responsibilities upon sale

When the MCWP is sold, the dealer:

- a) Shall, upon delivery, ensure the operating and maintenance manuals are conveyed to the owner.
- b) Shall, upon delivery, provide a copy of the current Manual of Responsibilities for Dealers, Owners, Users, Operators, Lessors and Lessees and Brokers of MCWPs.
- c) Should, within sixty (60) days of sale, provide maintenance and parts manuals.
- d) Shall, within sixty (60) days of the sale, notify the manufacturer (remanufacturer) or its successor (if existing) of the sale, providing the full name and address of the purchaser.
- e) Should, if the MCWP is used, accomplish an annual machine inspection prior to

delivery and provide a copy to the purchaser within sixty (60) days of the sale.

- f) Shall, upon delivery, familiarize the person designated by the receiving entity with the MCWP being acquired.

7.3.13 Modifications

Modifications or alterations of MCWP's shall be made only with prior written permission of the manufacturer. Should the manufacturer no longer be in business modifications or alterations shall be made only with written instruction from an equivalent entity.

7.3.14 Manufacturer's safety bulletins

The dealer shall comply with safety related bulletins as received from the manufacturer.

7.4 Responsibility of owners

7.4.1 Basic principles

Sound principles of safety, training, inspection, erection, maintenance, application, and operation consistent with all data available regarding the parameters of intended use and expected environment shall be applied in the performance of the responsibilities of owners with due consideration of knowledge that the unit will be carrying personnel.

7.4.2 Responsibilities upon purchase

Upon purchase of the MCWP, the buyer:

- a) Shall ensure the operating and maintenance manuals have been received.
- b) Should acquire maintenance and parts manuals within sixty (60) days of acquisition.
- c) Shall within sixty (60) days of acquisition of the MCWP provide the manufacturer, remanufacturer or its successors, with the full name and address of the buyer along with the model and serial number of the MCWP acquired.
- d) Shall, if the MCWP is used, ensure that frequent and annual inspections are current.
- e) Shall become familiar with and conform with the responsibilities of owners as set forth in the Manual of Responsibilities for MCWP's.

7.4.3 Manuals

Owners shall keep and maintain copy(ies) of the operating and maintenance manual(s) required in

this Standard. Copy(ies) of operating manual(s) shall be provided upon each rental or lease delivery. Copy(ies) of operating and maintenance manual(s) shall be provided upon each sale delivery. The operating manual(s) shall be stored in the location required in this Standard. These manual(s) are considered an integral part of the MCWP and are vital to communicate necessary safety information to users and operators.

7.4.4 Maintenance

The owner of a MCWP shall arrange that the maintenance specified in this Standard is properly performed on a timely basis by a qualified person. The owner shall establish a preventive maintenance program in accordance with the manufacturer's recommendations and based on the environment and severity of use of the MCWP. The owner shall arrange that frequent and annual inspections are performed. All malfunctions and problems noted shall be corrected before the MCWP is returned to service.

7.4.5 Frequent inspection

The owner of a MCWP shall cause a FREQUENT INSPECTION to be performed on the MCWP:

- a) That has been in service for three (3) months.
- b) That has been out of service for a period longer than three (3) months.

The inspection shall be made by a person qualified on the specific make and model of the MCWP. The inspection shall include all items specified by the manufacturer for a FREQUENT INSPECTION and shall include but not be limited to the following:

- a) All functions and their controls for speed(s), smoothness, and limits of motion.
- b) Emergency lowering means.
- c) All chain and cable mechanisms for adjustment and worn or damaged parts.
- d) All emergency and safety devices.
- e) Lubrication of all moving parts, as specified by the manufacturer.
- f) Visual inspection of structural components and other critical components such as fasteners, pins, shafts, locking devices, bolts, nuts, and tie assemblies.
- g) Placards, warnings, and control markings.

- h) Items specified by the manufacturer.
- i) Correction of all malfunctions and problems identified and further inspection if necessary, before continuing use.

7.4.6 Annual inspection

The owner of a MCWP shall cause an ANNUAL INSPECTION to be, performed on the MCWP no later than thirteen (13) months from the date of the prior annual inspection. The inspection shall be made by a person qualified on the specific make and model of the MCWP. The inspection shall include all items specified by the manufacturer for an ANNUAL INSPECTION.

7.4.7 Maintenance safety precautions

Before adjustments and repairs are started on a MCWP, the following precautions shall be taken as applicable:

- a) All controls in the "OFF" position and all operating features secured from inadvertent motion by brakes, blocks, or other means.
- b) Platform lowered to the full down position, if possible, or otherwise secured by blocking or cribbing to prevent dropping.
- c) Hydraulic oil/pneumatic pressure relieved from all hydraulic/pneumatic circuits before loosening or removing hydraulic/pneumatic components.
- d) Safety props or latches installed where applicable as described by the manufacturer.
- e) All electrical circuits shall be de energized by a locking device or by lock out/tag out system to protect against electrical shock during maintenance.
- f) Limit access to maintenance work area by unauthorized persons.

7.4.8 Replacement parts

When parts or components are replaced, they shall be identical or equivalent to original MCWP parts or components.

7.4.9 Maintenance training

The owner shall train his maintenance personnel in inspection and maintenance of the MCWP in accordance with Sections 7.4. 4, 7.4. 5, 7.4. 6, 7.4. 7, and 7.4. 8 of this Standard and with the manufacturer's recommendations

7.4.10 Operator training

Whenever an owner directs or authorizes an individual to operate a MCWP he shall ensure that the individual has been trained in accordance with the manufacturer's operating manual, and requirements listed in Section 7.6 of this Standard before operating the MCWP.

7.4.10.1 Familiarization on delivery

Upon delivery for lease, rental or any form of beneficial use, the owner shall have the responsibility with the person designated by the receiving entity for accepting the MCWP to:

- a) Identify the weather resistant compartment (for manual storage).
- b) Confirm that the manuals, as specified by the manufacturer, are on the MCWP.
- c) Review control functions with the operator or person(s) designated by the user.
- d) Review safety devices specific to the MCWP delivered.

7.4.11 Operation

When an owner operates a MCWP, he shall have the responsibilities of users as specified in Section 7.5 of this Standard and his operating personnel shall have responsibilities of operators as specified in Section 7.6 of this Standard.

7.4.12 Assistance to users and operators

If an owner is unable to answer a user's or operator's questions relating to rated load, intended use, maintenance, repair, inspection, or operation of the MCWP, the owner shall obtain the proper information from the dealer or manufacturer, or equivalent entity should the dealer or manufacturer not be available or able to provide said answer, and provide that information to the user or operator.

7.4.13 Record retention and dissemination

7.4.13.1 Record retention

The owner shall retain the following records for at least three years.

- a) Name and addresses of the subsequent purchaser of each MCWP by serial number and date of delivery.
- b) Records of the person(s) trained upon each delivery of a MCWP.
- c) Name(s) of personnel providing training.

d) Names of person(s) receiving familiarization upon delivery, unless the individual has been provided with familiarization on the same model, or one having characteristics consistent with the one being delivered, within the prior ninety (90) days.

e) Name of person(s) providing familiarization upon delivery.

f) Written records of the FREQUENT and ANNUAL INSPECTIONS shall be kept by the owner when he performs the inspection. The record shall include deficiencies found, corrective action and identification of the person(s) performing the inspection and repairs.g) Records of the pre-delivery inspection performed prior to each delivery.

7.4.13.2 Proof of training

Owners providing training should provide successful trainees a means to evidence their training and shall provide such proof if requested by the trainee. The document evidencing training shall include the following information:

- a) Name of trainee.
- b) Name of entity providing training or retraining.
- c) Name of trainer(s).
- d) Clear identification that training covered MCWP's.
- e) Date of training.

7.4.13.3 Record dissemination

Upon request, an owner accomplishing training and/or familiarization shall provide for the following:

- a) To a user, proof of training for an operator, including name of trainer and date of training.
- b) To a user, the name of the person(s) receiving familiarization upon delivery of the MCWP.

7.4.14 Modifications

Modifications or alterations of MCWP's shall be made only with prior written permission of the manufacturer. Should the manufacturer no longer be in business modifications or alterations shall be made only with written instruction from an equivalent entity.

7.4.15 Manufacturer's safety bulletins

The owner shall comply with safety related bulletins as received from the manufacturer or dealer.

7.4.16 Responsibilities upon sale

Upon sale of the MCWP, the seller :

- a) Shall, upon delivery, ensure the operating and maintenance manuals are conveyed to the new owner.
- b) Shall, upon delivery, provide a copy of the current Manual of Responsibilities for Dealers, Owners, Users, Operators, Lessors and Lessees and Brokers of MCWP's to the new owner.
- c) Should provide maintenance and parts manuals to the new owner.
- d) Shall, upon the request of the new owner, offer to do training or advise where training may reasonably be obtained.

7.5 Responsibilities of users

7.5.1 Basic principles

The information in this Standard must be supplemented by good job management, safety control, and the application of sound principles of safety, training, inspection, erection, maintenance, application and operation consistent with all data available regarding the parameters of intended use and expected environment. Since the user has direct control over the application and operation of MCWP's, conformance with good safety practices in this area is the responsibility of the user and his operating personnel including the operator. Decisions on the use and operation of the MCWP must always be made with due consideration for the fact that the machine will be carrying personnel whose safety is dependent on those decisions.

7.5.2 Erection principles

7.5.2.1 Support structure Integrity analysis

The building or structure and attachments shall be assessed by a qualified person to insure that it can withstand the loading imposed upon it by the MCWP.

NOTE the above requirement is waived when the machine is designed to be Free Standing.

7.5.2.2 Base/chassis support

Each MCWP shall be supported by a firm foundation of such strength and dimensions as will adequately distribute the transmitted load so as not to exceed the safe load bearing capacity of the surface upon which such platforms are erected.

7.5.2.3 Attachments

The MCWP shall be properly tied to the building or support structure unless it is designed to be free standing. Tie Assembly(ies) shall conform to, or be equal to, the manufacturer's specifications and shall remain in place until the mast(s) is(are) dismantled.

7.5.2.4 Electrical supply circuit

Appropriate lock out/tag out system shall be implemented for the supply circuit (power source circuit).

7.5.2.5 Overhead restrictions

Prior to erection, the travel area of the MCWP shall be checked for overhead obstructions and minimum safe approach distance to energized overhead power lines.

7.5.3 Manuals

Users shall keep and maintain copy(ies) of the operating manual(s) required in this Standard. The operating manual(s) shall be stored in the location required in this Standard. These manuals are considered an integral part of the MCWP and are vital to communication of necessary safety information to users and operators.

7.5.4 Inspection and maintenance

Users shall inspect and maintain the MCWP as required to ensure proper operation. The frequency of inspection and maintenance shall be determined by manufacturer's recommendation and be compatible with operating conditions and the severity of the operating environment. MCWP's that are not in proper operating condition shall be immediately removed from service until repaired. Repairs shall be made by a qualified person and the repairs shall be in conformance with the manufacturer's recommendations, or equivalent entity person's recommendations should the manufacturer no longer be in business.

7.5.4.1 Frequent inspection

An inspection as outlined in section 7.4.5 of this Standard shall be conducted.

7.5.4.2 Annual inspection

An inspection as outlined in section 7.4.6 of this Standard shall be conducted.

7.5.4.3 Pre start inspection

Before use each day or at the beginning of each shift, the MCWP shall be given a visual inspection and functional test including but not limited to the following:

- a) Operating and emergency controls, including but not limited to brakes, and limit devices.
- b) Safety devices.
- c) Air, hydraulic and fuel system leaks.
- d) Cables and wiring harness.
- e) Loose or missing parts.
- f) Tires and wheels.
- g) Placards, warnings, and control markings.
- h) Outriggers, stabilizers, and other structures.
- i) Guardrail system.
- j) Mast guards.
- k) Mast sections.
- l) Attachments.
- m) Platform extensions.
- n) Items specified by the manufacturer.
- o) Correction of all malfunctions and problems identified and further inspection if necessary, before continued use.

7.5.4.4 Maintenance safety precautions

Before adjustments and repairs are started on a MCWP, the following precautions shall be taken as applicable:

- a) All controls in the OFF position and all operating features secured from inadvertent motion by brakes, blocks, or other means.
- b) Powerplant stopped and starting means rendered inoperative.
- c) Platform lowered to the full down position, if possible, or otherwise secured by blocking or cribbing to prevent dropping.
- d) Hydraulic oil/pneumatic pressure relieved from all hydraulic/pneumatic circuits before loosening or removing hydraulic/ pneumatic components.
- e) Safety props or latches installed where applicable as described by the manufacturer.
- f) Precautions specified by the manufacturer.

- g) All electrical circuits shall be de-energized by a locking device or by a lock out/tag out system to protect against electrical shock.
- h) Limit access to maintenance work area by unauthorized persons.

7.5.5 Replacement parts

When parts or components are replaced, they shall be identical or equivalent to original MCWP parts or components.

7.5.6 Maintenance training

The users shall ensure only qualified personnel inspect and maintain the MCWP in accordance with the manufacturer's recommendations and sections 7.5.2, 7.5.3, 7.5.4 and 7.5.5 of this Standard.

7.5.7 Operator training

Whenever a user directs or authorizes an individual to operate a MCWP, he shall ensure that the individual has been trained in accordance with the manufacturer's operating and maintenance manual, and the operators work instructions and requirements listed in section 7.6 of this Standard before operating the MCWP.

7.5.7.1 Operator training and retraining

Whenever a user directs or authorizes an individual to operate a MCWP the user shall ensure the person has been:

- a) Trained before being assigned to operate the MCWP.
- b) Familiarized with the MCWP to be operated.
- c) Made aware of responsibilities of operators as outlined in section 7.6 of this Standard
- d) Retrained, if necessary, based on the user's observation and evaluation of the operator.

7.5.7.2 Familiarization before use

The user shall permit only properly trained personnel to operate a MCWP. The user shall ensure that before use the operator is familiar with the model of the MCWP to be operated, and specifically:

- a) Knows where the weather resistant compartment for manual storage is located.
- b) Knows the operating and maintenance manuals supplied by the manufacturer (remanufacturer) are stored in the weather resistant compartment and is familiar with the operating and safety manuals.

- c) Understands all control functions, placards and warnings.
- d) Is aware of and understands all safety devices specific to the model of MCWP being used.

7.5.7.3 Trainees training record

A record of the trainee's MCWP instruction shall be maintained by the user for at least three years.

7.5.8 Before operation

Before authorizing an operator to operate a MCWP, the user shall ensure that the operator has:

- a) Been instructed by a qualified person in the intended purpose and function of each control.
- b) Has read and understood the manufacturer's operating instructions and user's safety rules, or been trained by a qualified person on the contents of the manufacturer's operating instructions and user's safety rules.
- c) Understood by reading or by having a qualified person explain all decals, warnings, and instructions displayed on the MCWP.
- d) Determined that the purpose for which the MCWP is to be used is within the scope of the intended applications defined by the manufacturer.

7.5.9 Work place inspection

Before the MCWP is used and during use, the user shall check the area in which the MCWP is to be used for possible hazards such as but not limited to:

- a) Drop off or holes.
- b) Bumps and floor obstructions.
- c) Debris.
- d) High voltage lines.
- e) Hazardous locations.
- f) Inadequate surface and support to withstand all load forces imposed by the MCWP in all operating configurations.
- g) Wind and weather conditions.
- h) Attachments.
- i) Presence of unauthorized persons.
- j) Vehicular traffic.
- k) Other possible unsafe conditions.

7.5.10 During operation

The MCWP shall be used in accordance with this Standard and the manufacturer's instructions. The user shall direct the operator

to ensure the following before each elevation of the platform:

- a) That the MCWP is operated on a surface within the limits specified by the manufacturer.
- b) That the outriggers, stabilizers, extendable axles, or other stabilizing methods, are used as required by the manufacturer.
- c) That the MCWP shall be properly tied to the building or other structures being worked at unless the machine is designed to be free standing.
- d) That guardrails and mast guards are installed and access gates or openings are closed per manufacturer's instructions.
- e) That the load and its distribution on the platform and any platform extension are in accordance with the manufacturer's rated work load for that specific configuration.
- f) That there is adequate clearance from overhead obstructions.
- g) That the minimum safe approach distances (M.S.A.D.) to energized power lines and parts, as listed in Appendix D.
- h) That the precautions defined in Sections 7.6.3, 7.6.4, 7.6.7, 7.6.8, 7.6.9, and 7.6.10 of this Standard and manufacturer's instructions are followed during operation of the MCWP.
- i) That fall protection devices are used by all personnel on the platform if any section of the guardrail system has been removed from an exposed side of the platform.

7.5.11 Determination of hazardous locations

It shall be the responsibility of the user to determine the hazard classification of any particular atmosphere or location according to ANSI/NFPA 505.

7.5.11.1 Hazardous location operating requirements

MCWP's operated in hazardous locations shall be approved and of the type required by ANSI/NFPA 505.

7.5.12 Warnings and instruction

The user shall direct his operating personnel and supervise the work to ensure operation in compliance with the following:

7.5.12.1 Personnel footing

Personnel shall maintain a firm footing on the platform floor while working thereon. Use of ladders on the MCWP for achieving additional height or reach shall be prohibited. Any other

device to achieve additional height shall be used only with written approval of the manufacturer.

7.5.12.2 Other moving equipment

When other moving equipment or vehicles are present, special precautions shall be taken to comply with local ordinances or safety standards established for the work place. Warnings such as, but not limited to flags, roped off areas, flashing lights, and barricades shall be used.

7.5.12.3 Reporting problems or malfunctions

The user shall direct the operator to immediately report to his supervisor any problems or malfunctions which become evident during operation. Any problems or malfunctions that affect the safety or operations shall be repaired prior to continued use of the MCWP.

7.5.12.4 Altering safety devices

Altering or disabling of interlocks, limit switches, or other safety devices shall be prohibited.

7.5.12.5 Entanglement

Care shall be taken to prevent rope, electric cords, hoses, etc., from becoming entangled in the MCWP.

7.5.12.6 Capacity limitation

MCWP rated work load shall not be exceeded when loads are transferred to the platform at any height.

7.5.12.7 Work area

The user shall direct the operator to ensure that the area surrounding the MCWP is clear of personnel and equipment before lowering the platform.

7.5.12.8 Misuse

The MCWP shall not be used as a crane, or personnel/material hoist.

7.5.12.9 Operating areas

The MCWP shall not be operated from a position on trucks, trailers, railway cars, floating vessels, scaffolds, or similar equipment unless the application is approved in writing by the manufacturer.

7.5.12.10 Travel conditions

Under all travel conditions, the operator shall limit travel speed according to conditions of ground surface, congestion, visibility, slope, location of personnel, and other factors causing hazards of collision or injury to personnel.

7.5.12.11 Unauthorized use

When applicable, means shall be used to protect against use by unauthorized person(s).

7.5.12.12 Electrocuting hazard

All applicable safety related work practices intended to prevent electric shock covered by the Code of Federal Regulations (CFR) 1910.333 shall be defined and explained to the operator by a qualified person. In particular, such person shall direct the operator, commensurate with the operator's qualifications to maintain the appropriate minimum safe approach distance covered by CFR 1910.333 and Annex D.

7.5.13 Operation of MCWP

If a user is also the operator of a MCWP, he shall have the responsibilities of operators specified in section 7.6 of this Standard as well as responsibilities of users as specified in section 7.5 of this Standard.

7.5.14 Assistance to operator

If a user is unable to answer any operators questions relating to rated work load, intended use, maintenance, erection conditions of the MCWP or safety of operation of the MCWP, the user shall obtain the proper information from the dealer, owner, manufacturer, or equivalent entity should the manufacturer no longer be in business, and provide that information to the operator before use of the MCWP in the application of concern.

7.5.15 Shutdown of mast climbing work platform

The user shall authorize and direct his operating personnel to cease operation of the MCWP in case of any suspected malfunctions of the MCWP, or any hazard or potentially unsafe condition that may be encountered, and to request further information as to safe operation from the owner, dealer, or manufacturer before further operation of the Mast Climbing Work Platform

7.5.16 Record retention and dissemination**7.5.16.1 Record retention**

The user shall retain the following records for at least four (4) years:

- a) Name(s) of the operator(s) trained and retrained.
- b) Names of operator(s) provided with familiarization.
- c) The owner (or the entity designated by the owner) is responsible to ensure frequent and annual inspections are conducted and written records are maintained. The records shall include the date of the inspection, any deficiencies found, the corrective action recommended and identification of the person(s) performing the inspection. When the user accomplishes an inspection, they shall be responsible to ensure only qualified personnel inspect and that all such records are maintained for the four (4) years specified above.
- d) When employees of the user accomplish repairs on the MCWP, the user shall maintain written records. The records shall indicate the date of the repair, a description of the work accomplished and identification of the person(s) performing the repair.

7.5.16.2 Record dissemination

- a) When the user directs personnel to accomplish frequent or annual inspections, not later than sixty (60) days after the inspections, the appropriate records shall be provided to the owner of the MCWP.
- b) When the user directs personnel to accomplish repairs on the MCWP, not later than sixty (60) days after the repairs are accomplished, the appropriate records shall be provided to the owner.

7.5.16.3 Proof of training

Users providing training should provide successful trainees a means to evidence their training and shall provide such proof if requested by the trainee. The document evidencing training shall include the following information:

- a) Name of trainee.
- b) Name of entity providing training or retraining.
- c) Name of trainer(s).
- d) Clear identification that training covered MCWP's.

- e) Date of training.

7.5.17 Modifications

A user shall not modify or concur in modification of a MCWP without the specific written approval of the manufacturer, or equivalent entity should the manufacturer no longer be in business, of the MCWP.

7.5.18 Manufactures safety bulletins

The user shall comply with safety related bulletins as received from the manufacturer, dealer, or owner.

7.6. Responsibilities of operators

7.6.1 Basic principles

The information in this Standard must be supplemented by good judgement, safety control, and caution in evaluating each situation. Since the operator is in direct control of the MCWP, conformance with good safety practices in this area is the responsibility of the operator. The operator must make decisions on the use and operation of the MCWP with due consideration for the fact that his own safety as well as the safety of other personnel on and around the platform is dependent on these decisions.

7.6.2 Manuals

The operator shall be aware that the operating and safety manuals, including the manual which defines the responsibilities of dealers, owners, lessors, lessees, users and operators are stored on the MCWP and the location where they are stored. The operator shall be familiar with the manuals stored on the MCWP and consult them when questions arise with respect to the MCWP.

7.6.3 Pre-start inspection

Before use each day or at the beginning of each shift, the MCWP shall be given a visual inspection and functional test including but not limited to the following:

- a) Operating and emergency controls, including but not limited to brakes, and limit devices.
- b) Safety devices.
- c) Air, hydraulic and fuel system leaks.
- d) Cables and wiring harness.
- e) Loose or missing parts.
- f) Tires and wheels.

- g) Placards, warnings, and control markings.
- h) Outriggers, stabilizers, and other structures.
- i) Guardrail system.
- j) Mast guards.
- k) Mast sections.
- l) Attachments.
- m) Platform extensions.
- n) Items specified by the manufacturer.
- o) Correction of all malfunctions and problems identified and further inspection if necessary, before continued use.

7.6.4 Problems or malfunctions

Any problems or malfunctions that affect the safety of operations shall be repaired prior to the use of the MCWP.

7.6.5 Training, retraining and familiarization

7.6.5.1 General training

Only personnel who have received general instructions regarding inspection, application and operation of MCWP's, including recognition and avoidance of hazards associated with their operation, shall operate a MCWP. Such items covered shall include, but not necessarily be limited to, the following issues and requirements:

- a) The purpose and use of manuals.
- b) That operating manuals are an integral part of the MCWP and must be stored properly in the weather resistant compartment when not in use.
- c) A pre-start inspection.
- d) Responsibilities associated with problems or malfunctions affecting the operation of the MCWP.
- e) Factors affecting stability.
- f) The purpose of placards and decals.
- g) Workplace inspection.
- h) Safety rules and regulations.
- i) Authorization to operate.
- j) Operator warnings and instructions.
- k) Actual operation of the MCWP. Under the direction of a qualified person, the trainee shall operate the MCWP for a sufficient period of time to demonstrate proficiency in the actual operation of the MCWP.

7.6.5.2 Retraining

The operator shall be retrained, when so directed by the user, based on the user's observation and evaluation of the operator.

7.6.5.3 Familiarization

When an operator is directed to operate a MCWP he/she is not familiar with, the operator shall receive instructions regarding the following items:

- a) The location of the weather resistant compartment (for manual storage).
- b) The purpose and function of all controls.
- c) Safety devices and operating characteristics specific to the MCWP.

7.6.6 Before operation

Before being authorized to operate the MCWP, the operator shall have:

- a) Been instructed by a qualified person in the intended purpose and function of each of the controls.
- b) Read and understood the manufacturer's/owner's operating instructions and safety rules, or been trained by a qualified person on the contents of the manufacturers/owner's operating instructions and safety rules.
- c) Understood by reading or having a qualified person explain all decals, warnings, and instructions displayed on the MCWP.

7.6.7 Work place inspection

Before the MCWP is used and during use, the operator shall check the area in which the MCWP is to be used for possible hazards such as, but not limited to:

- a) Drop offs or holes.
- b) Bumps and floor obstructions.
- c) Debris.
- d) Overhead obstructions and high voltage conductors.
- e) Hazardous locations.
- f) Inadequate surface and support to withstand all load forces imposed by the MCWP in all operating configurations.
- g) Wind and weather conditions.
- h) Vehicular traffic.
- i) Attachments of building ties.
- j) Other possible unsafe conditions.
- k) Presence of unauthorized persons.

7.6.8 During operation

The MCWP shall be used in accordance with this Standard. The operator shall ensure the following before each elevation of the platform:

- a) That the MCWP is operated on a surface within the limits specified by the manufacturer.

b) That the outriggers, stabilizers, extendable axles, or other stability enhancing means are used as required by the manufacturer.

c) That guardrails and mast guards are installed and access gates or openings are closed per manufacturer's instructions.

d) That the load and its distribution on the platform and any platform extensions are in accordance with the specific configuration.

e) That there is adequate clearance from overhead obstructions.

f) That the minimum safe approach distances (M.S.A.D.) to energized power lines and parts, as listed in Appendix D.

g) That fall protection devices are used by all personnel on the platform if any section of the guardrail system has been removed from an exposed side of the platform.

7.6.9 Determination of hazardous locations

It shall be the responsibility of the user to determine the hazard classification of any particular atmosphere or location according to ANSI/NFPA 505.

7.6.9.1 Hazardous location operating requirements

MCWP operated in hazardous locations shall be approved and of the type required by ANSI/NFPA 505.

7.6.10 Warnings and instructions

The operator and other personnel in the platform shall comply with the following:

7.6.10.1 Personnel footing

Personnel shall maintain a firm footing on the platform floor while working therein. Use of ladders on the MCWP for achieving additional height or reach shall be prohibited. Any other device to achieve additional height shall be used only with the written approval of the manufacturer.

7.6.10.2 Other moving equipment

When other moving equipment or vehicles are present, special precautions shall be taken to comply with local ordinances or safety standards established for the work place. Warnings such as, but not limited to, flags, roped off areas, flashing lights, and barricades shall be used.

7.6.10.3 Reporting problems or malfunctions

The operator shall immediately report to his supervisor any problems or malfunctions which become evident during operation. Any problems or malfunctions that affect the safety of operation shall be repaired prior to continued use of the MCWP.

7.6.10.4 Reporting potentially hazardous locations

The operator shall immediately report to his supervisor any potential hazards which become evident during operation.

7.6.10.5 Altering safety devices

Altering or disabling of interlocks, limit switches, or other safety devices shall be prohibited.

7.6.10.6 Entanglement

Care shall be taken to prevent rope, electric cords, hoses, etc. from becoming entangled in the MCWP.

7.6.10.7 Work load limitation

MCWP rated work load shall not be exceeded when loads are transferred to the platform at any height.

7.6.10.8 Work area

The operator shall ensure that the area surrounding the MCWP is clear of personnel and equipment before lowering the platform.

7.6.10.9 Misuse

The MCWP shall not be used as a crane, or personnel/material hoist.

7.6.10.10 Operating areas

The MCWP shall not be operated from a position on trucks, trailers, railway cars, floating vessels, scaffolds, or similar equipment unless the application is approved in writing by the manufacturer.

7.6.10.11 Travel conditions

Under all travel conditions, the operator shall limit travel speed according to conditions of ground surface, congestion, visibility, slope, location of personnel, and other factors causing hazards of collision or injury to personnel.

7.6.10.12 Unauthorized use

When applicable, means shall be used to protect against use by unauthorized person(s).

7.6.10.13 Misuse as a jack

The platform of the MCWP shall not be used to jack the wheels off the ground unless the machine is designed for that purpose by the manufacturer.

7.6.10.14 Snagged platform

If the platform or elevating assembly becomes caught, snagged or is otherwise prevented from normal motion by adjacent structure or other obstacles such that control reversal does not free the platform, all personnel shall be removed from the platform before attempts are made to free the platform.

7.6.11 Assistance to operator

If an operator encounters any suspected malfunction of the MCWP, or any hazard or potentially unsafe condition relating to work load, operator shall cease operation of the MCWP and request further information as to safe operation from his management, or the owner, dealer, or manufacturer before further operation of the MCWP.

7.6.12 Modifications

Modifications or alterations of MCWP's shall be made only with prior written permission of the manufacturer. Should the manufacturer no longer be in business modifications or alterations shall be made only with written instruction from an equivalent entity.

7.6.13 Electrocutation hazard

All applicable safety related work practices intended to prevent electric shock covered by the Code of Federal Regulations (CFR) 1910.333 shall be defined and explained to the operator by a qualified person. In particular, such person shall direct the operator, commensurate with the operator's qualifications to maintain the appropriate minimum safe approach distance covered by CFR 1910.333 and Annex D.

7.7 Responsibilities of lessors

7.7.1 Basic principles

Sound principles of safety, training, inspection, erection, maintenance, application, and operation consistent with all data available

regarding the parameters of intended use and expected environment shall be applied in the performance of responsibilities of lessors with due consideration of the knowledge that the unit shall be carrying personnel.

7.7.2 Lessor

7.7.2.1 Lessor as a dealer

When a lessor uses the MCWP as a dealer, the lessor shall have the responsibilities of dealers as specified in section 7.3 of this Standard.

7.7.2.2 Lessor as an owner

When a lessor uses the MCWP as an owner, the lessor shall have the responsibilities of owners as specified in section 7.4 of this Standard.

7.7.2.3 Lessor as a user

When a lessor uses the MCWP as a user, the lessor shall have the responsibilities of users as specified in section 7.5 of this Standard.

7.7.2.4 Lessor as an operator

When a lessor uses the MCWP as an operator, the lessor shall have the responsibilities of operators as specified in section 7.6 of this Standard.

7.8 Responsibilities of lessee

7.8.1 Basic principles

Sound principles of safety, training, inspection, erection, maintenance, application, and operation consistent with all data available regarding the parameters of intended use and expected environment shall be applied in the performance of responsibilities of lessee with due consideration of the knowledge that the unit shall be carrying personnel.

7.8.2 Lessee

7.8.2.1 Lessee as a dealer

When a lessee uses the MCWP as a dealer, the lessee shall have the responsibilities of dealers as specified in section 7.3 of this Standard.

7.8.2.2 Lessee as an owner

When a lessee uses the MCWP as a owner, the lessee shall have the responsibilities of

owners as specified in section 7.4 of this Standard.

7.8.2.3 Lessee as a user

When a lessee uses the MCWP as a user, the lessee shall have the responsibilities of users as specified in section 7.5 of this Standard.

7.8.2.4 Lessee as an operator

When a lessee uses the MCWP as an operator, the lessee shall have the responsibilities of operators as specified in section 7.6 of this Standard.

7.9 Responsibilities of brokers

7.9.1 Responsibilities upon sale

The broker shall:

- a) Upon delivery, ensure the operating and maintenance manuals are provided to the new owner.
- b) Upon delivery, provide a copy of the current Manual of Responsibilities for Dealers, Owners, Users, Operators, Lessors and Lessees and Brokers of MCWP's to the new owner.
- c) Maintain records of the sale for a minimum of four (4) years.

7.9.2 Responsibilities with re-rents, leases or any other form of beneficial use.

When compensation is received as a result of a re-rent, lease or any form of beneficial use of a MCWP the broker shall:

- a) Upon delivery, ensure the operating and maintenance manuals are provided to the user.
- b) Upon delivery, provide a copy of the current Manual of Responsibilities for Dealers, Owners, Users, Operators, Lessors and Lessees and Brokers of MCWP's.
- c) Ensure operating personnel are familiarized with the MCWP prior to use.
- d) Retain records of the transaction for a minimum of four (4) years.

Annex A

Structural calculations

General

The calculation should conform with the rules and principles of applied mechanics and strength of materials. If special formulae are used, the sources should be given, if they are generally available. Otherwise the formulae should be developed from first principles, so that their validity can be checked.

A.1 In the absence of a standard for design calculation the following guidelines may be used for the design of steel structures.

A.1.1 Allowable stresses

Symbols	f_y	yield strength [psi (N/mm ²)]
	f_u	ultimate strength [psi (N/mm ²)]
	$E = 29 \times 10^6$ psi (200,000)	modulus of elasticity [psi (N/mm ²)]
	$G = E/(2x(1+v))$	shear modulus [psi (N/mm ²)]
	$\nu = 0.3$	Poisson's ratio
	δ	elongation at failure on gauge length of 2 inches [51mm] of the test specimen [%]
	S	Safety factor on yield strength

A.1.1.1 Non-alloy structural steels according to American Society for Testing and Materials

Table A.1: Nominal values of material properties

Type	Yield ¹⁾ Strength f_y psi [N/mm ²]	Ultimate ²⁾ Strength f_u psi [N/mm ²]
ASTM A36	36,000 [248]	58,000 [400]
ASTM A529	42,000 [280]	62,000 [427]
ASTM A572	50,000 [345]	65,000 [448]
1	Standard value for small thickness	
2	Minimum	

A.1.1.1.1 Allowable stresses for non-alloy structural steels

$$F_o = f_y/S$$

Table A.2 Allowable stresses for non-alloy structural steels; psi[N/mm²]

Load Case	A psi [N/mm ²]			B psi [N/mm ²]			C psi [N/mm ²]		
S	1.5			1.33			1.25		
Steel grade	36,000 [248]	42,000 [280]	50,000 [345]	36,000 [248]	42,000 [280]	50,000 [345]	36,000 [248]	42,000 [280]	50,000 [345]
Basic material and butt weld									
$F_a=F_o$	24,000 [165]	28,000 [193]	33,334 [230]	27,067 [187]	31,580 [218]	37,594 [259]	28,800 [198]	33,360 [232]	40,000 [275]
$F_v=F_o/\sqrt{3}$	13,856 [95]	16,165 [111]	19,245 [133]	15,627 [108]	18,233 [126]	21,705 [150]	16,628 [115]	19,260 [133]	23,094 [159]
Fillet Weld									
$F_a=F_o$	24,000 [165]	28,000 [193]	33,334 [230]	27,067 [187]	31,580 [218]	37,594 [259]	28,800 [198]	33,360 [232]	40,000 [275]
$F_v=F_o/\sqrt{2}$	16,970 [117]	19,800 [136]	23,570 [163]	19,140 [132]	22,330 [154]	26,583 [183]	20,365 [140]	23,590 [162]	28,284 [195]
The indicated permissible stresses are valid up to a thickness of 1-1/2". In the case of larger thickness the corresponding value of f_y should be taken into consideration.									

When selecting the materials special requirements should be taken into account, e.g.:

- weldability
- use of the appliance in extreme climatic zones

1. A.1.1.2 Other steel grades

Steels of greater or lesser strength than those specified by Table A.1 may be used provided they have an elongation of not less than 20% in a length of 2" [51mm]. The stresses specified in Table A.2 may be increased proportionately based on the ratio of the ultimate strengths.

Annex B

Special requirements for multilevel work platforms

See Tables B.1 and B.2.

Table 1 — Option A

OPTION A Mounted on and/or below the primary work platform		
Requirements	Single mast	Multiple masts
		
Allow for the effect on calculations/Rated load	Allow for mass of multilevel work platform	
Allow for additional forces on mast and mast ties	Yes	Yes
Allow for additional in- and out-of-service wind forces	Yes	Yes
Allow for the effect on stability	Yes	Yes
Guardrails and toeboards	Yes	Yes
Ladder	Yes	Yes
Trap door	Yes	Yes
Fixings and stability of subsidiary work platform in relation to the primary work platform	Yes, by adequate fixings to primary work platform	
Supported on primary work platform or on platform extensions or both	Yes, any combination	
Platform levelling	According to 5.3.1.1	According to 5.3.1.1 with assurance that clearance remains between subsidiary work platform and mast for full leveling range
Controls	Visibility shall remain at control point	
Protection from falling objects	NA	
Emergency lowering	Standard arrangements	
Buffers	According to 5.3.4 i) and Instruction handbook	
Upper travel limit switch	Standard arrangements	
Lower travel limit switch	Special adjustment when subsidiary work platform is below primary work platform	
Separation distance between work platforms	Fixed separation ≥ 3 m For minimum clearance see 5.3.4.e)	
Safety devices against falling (see 5.5)	Allow for any extra load	
Instruction handbook	Full information shall be given on how to erect and dismantle and on the use of the multilevel platform	
NA = Not applicable		

Annex B

Table 2 —Option B

Requirements	Single mast	Multiple masts
Allow for the effect on calculations/Rated load	Independent calculation of each work platform	
Allow for additional forces on mast and mast ties	Yes	Yes
Allow for additional in- and out-of-service wind forces	Yes	Yes
Allow for the effect on stability	Yes	Yes
Guardrails and toeboards	Yes	Yes
Ladder	No – See 5.3.4.f)	
Trap door	NA	NA
Fixings and stability of subsidiary work platform in relation to the primary work platform	NA	NA
Supported on primary work platform or on platform extensions	NA	NA
Platform levelling	Separate arrangements for each platform	
Controls	Separate controls for each platform	
Protection from falling objects	Lower work platform(s) shall be protected from upper work platform – See 5.3.4 d) and Instruction handbook	
Emergency lowering	Standard arrangements	
Buffers	Standard buffers according to 5.4.6	
Upper travel limit switch	Separate switches for each platform	
Lower travel limit switch	Separate switches for each platform	
Separation distance between work platforms	See 5.3.4 e)	
Safety devices against falling (see 5.5)	Separate arrangements each work platform	
Instruction handbook	Full information shall be given on how to create and dismantle and on the use of the multilevel platform	
NA = Not applicable		

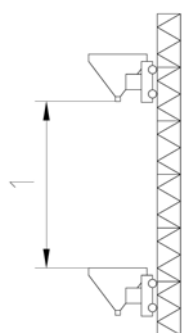

OPTION B
Two or more work platforms
separately driven on common mast(s)

Key
1

Annex C

Requirements for electrical and electronic aspects for overload-detection devices

C.1 Reliability

C.1.1 Electronic components shall be selected on the basis of the most unfavourable load, temperature and tolerance parameters.

C.1.2 The power consumption of electronic components shall not exceed 66 % of the power stated by the manufacturer at an ambient temperature outside the housing of + 60 °C.

C.1.3 Detection devices shall be such that their sound operation is not affected by ambient temperatures between – 20 °C and + 60 °C outside the housings. Within the range of these temperatures, deviation from the set value shall not exceed ± 3 %.

The design should take into account that, under the circumstances described, a temperature higher than + 60 °C can be reached inside the housing.

C.1.4 Electronic detection devices or their components shall be such that their operation is not affected by the following.

- a) Voltage pulses superimposed on the mains voltage:
 - Amplitude 1 000 V
 - Pulse duration 50 μ s (measured at 50 % of the peak value of the voltage pulse)
 - Rise time 0,2 μ s to 0,5 μ s
- b) Voltage pulses between mains and earth:
 - Amplitude 500 V
 - Pulse duration 100 ns (measured at 50 % of the peak value of the voltage pulse)
 - Rise time 10 ns
 - Pulse repetition rate 10 Hz
- c) Voltage pulses between inputs or outputs and earth (common mode):
 - Amplitude 500 V
 - Pulse duration 100 ns (measured at 50 % of the peak value of the voltage pulse)
 - Pulse repetition rate 10 Hz
 - Rise time 10 ns
- d) Alternating magnetic fields:
 - Magnetic field strength 400 A/m
 - Frequency 50 Hz
- e) Electromagnetic fields:
 - Strength 4 V/m
 - Frequency 100 kHz to 500 MHz

C.2 Reporting defects

C.2.1 The occurrence in a detection device of the defects given below in C.2.3 shall not cause inability to switch off the MCWP if the limit value is exceeded

C.2.2 The detection device shall be designed and connected to the electric installation of the MCWP in such a way that

- f) after the occurrence of one of the defects or actions given under C.2.3.1 a), the MCWP installation is automatically switched off and can no longer be started before the defect or interruption is eliminated, and
- g) after occurrence of one of the defects given under C.2.3.1 b) and after the MCWP is switched off, the MCWP can no longer be started before the defect is eliminated. This requirement does not apply if continued safe operation of the MCWP is automatically ensured by the detecting device.

The provisions under C.2.2 can be met by one of the following measures:

- design the circuit of the detecting device in such a way that the prescribed continued switched-off condition of the MCWP is achieved when a defect has developed;
- use a circuit to check the circuits in the detecting device for the presence of a defect; such a circuit shall be designed and connected in such a way that
 - the relevant test key shall be operated after each MCWP shut-down before the MCWP installation can be started, and
 - the MCWP installation cannot be started if there is a defect in the test circuit or in the detecting device;
- design multiple circuits in the detecting device and incorporate them in a test circuit; the test circuit shall be designed and connected in such a way that the MCWP is switched off if there is a defect in the test circuit or one of the parallel circuits of the detecting device;
- earth or connect to the frame of a circuit in which relays or solenoid switches are incorporated to ensure the MCWP is switched off if earth or frame leakage occurs.

C.2.3 Defects to be anticipated

C.2.3.1 The following defects can be anticipated, and subsequent actions shall be taken into account on the basis of C.2.1 and C.2.2.

- h) A break, dislodging or detachment of a cable forming the connection between the individual units of the installation which are mounted in cabinets, as evidenced by the following:
 - interruption or drop in (one of) the supply voltage(s) at any moment;
 - earth or frame leakage or interruption in the circuit;
 - relay contact or contactor failing to open or close;
 - auxiliary switch (such as a limit switch, hand operated switch, etc.) failing to open or close;
 - interruption or short-circuit in a signal transmitter (such as a potentiometer, strain-gauge bridge or transducer);

- interrupted connection of or short-circuit in a semiconductor component (such as a transistor, diode or optocoupler) or a capacitor;
- short-circuit or interruption in a resistor;
- a defect causing the output of an integrated circuit to give a positive or negative potential. If several similar circuits are mounted on a semiconductor printed circuit board, allowance shall be made for the same defect occurring simultaneously in all circuits.

NOTE Requirements for microprocessor applications are under consideration.

C.2.3.2 The provisions of C.2.3.1 do not apply to the following defects:

- short-circuit between the cores of a cable if the cable satisfies the requirements provided in the relevant national standard(s) and if the rated voltage of the auxiliary circuit does not exceed that of the cable;
- a contact not opening if the relay satisfies the requirements in IEC 60947-5-1 and proper protection against influences from the ambience is installed;
- a contactor contact not opening if the contact load does not exceed 25 % of its rated power and proper protection against influences from the ambience is installed;
- a control switch not opening which is forced open mechanically if the values specified by the manufacturer for electrical protection, rated power, method of installation, rate and angle of operation, etc. are taken into account for installation of the contact; bridging of an auxiliary switch by (an) insulation defect(s) (but do apply if this results from earth leakage or moisture, against which a waterproof housing is often a reasonable solution);
- interruption of or short-circuit between tracks of printed circuits if the printed circuits satisfy the applicable requirements specified in IEC 60065;
- short-circuit in an optocoupler if the creepage paths and air gaps between the connecting wires may be regarded as adequate and a test voltage of 2,8 kV can be sustained between the input and output circuits;
- interruption or short-circuit in a resistor if the resistor has an insulating paint coating, a reduction of the rated power up to approximately 66 % has been applied, and short-circuit of the resistor is otherwise also prevented (by, for example, its arrangement).

C.2.3.3 If more defects can occur in the detecting device due to a defect in a component, the provisions of C.2.1 and C.2.2 are then also applicable.

Annex D

Minimum Safe Approach Distance (M.S.A.D.)

When an unqualified person is working in an elevated position near overhead lines, the location shall be such that the person and the longest conductive object he or she may contact cannot come closer to any unguarded, energized overhead line than the distances in the following table. (Table D-1)

Voltage range (phase to phase)	Minimum safe approach distance	
	(Feet)	(Meters)
Up to 50kV	10	3.05
50kV to 200kV	15	4.57
200kV to 350kV	20	6.10
350kV to 500kV	25	7.62
500kV to 750kV	35	10.67
750kV to 1000kV	45	13.72

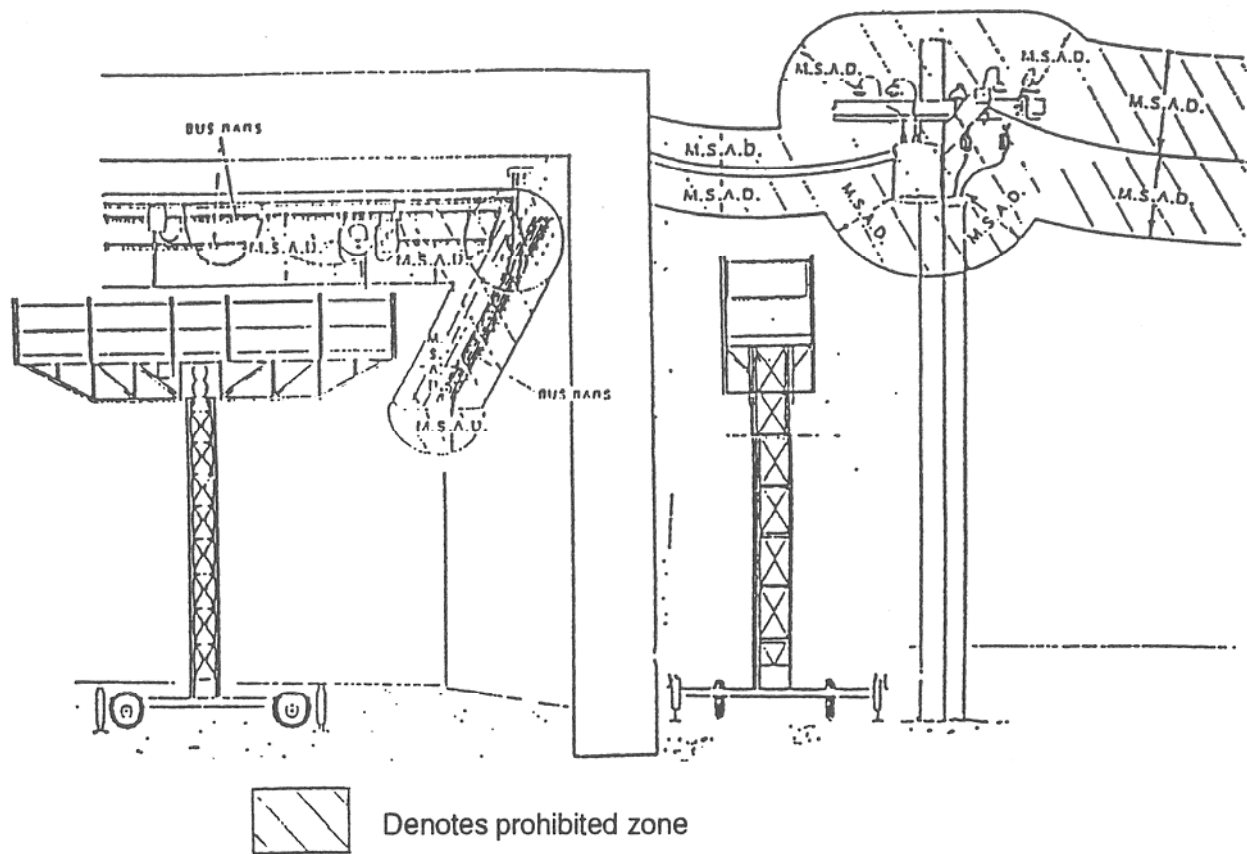

- Danger:**
- Do not allow machine personnel or conductive materials inside prohibited zone.
 - Maintain M.S.A.D. from all energized lines and parts as well as those shown.
 - Assume all electrical parts and wires are energized unless known otherwise.
- Caution:**
- Diagrams shown are only for purposes of illustrating M.S.A.D. work positions, not all work positions.